

## DLP6500FLQ 0.65 1080p MVSP Type A DMD

### 1 Features

- High resolution 1080p (1920×1080) Array with >2 Million Micromirrors
  - 0.65-Inch Micromirror Array Diagonal
  - 7.56  $\mu\text{m}$  Micromirror Pitch
  - $\pm 12^\circ$  Micromirror Tilt Angle (Relative to Flat State)
  - 2.5  $\mu\text{s}$  Micromirror Crossover Time
  - Designed for Corner Illumination
- Designed for Use With Broadband Visible Light (400 nm – 700 nm)
  - Window Transmission 97% (Single Pass, Through Two Window Surfaces)
  - Micromirror Reflectivity 88%
  - Array Diffraction Efficiency 86%
  - Array Fill Factor 92%
- Two 16-Bit, Low Voltage Differential Signaling (LVDS), Double Data Rate (DDR) input-data buses
- Dedicated DLPC900 Controller for high-speed pattern rates of 9500 Hz (1-Bit Binary) & 250 Hz (8-Bit Gray)
- Up to 400 MHz Input Data Clock Rate
- Integrated Micromirror Driver Circuitry
- Hermetic Package

### 2 Applications

- Industrial
  - 3D scanners for Machine Vision and Quality Control
  - 3D Printing
  - Direct Imaging Lithography
  - Laser Marking and repair
- Medical
  - Ophthalmology
  - 3D Scanners for Limb and Skin Measurement
  - Hyperspectral Imaging
- Displays
  - 3D Imaging Microscopes
  - Intelligent and Adaptive Lighting

### 3 Description

Featuring over 2 million micromirrors in a hermetic package, the high resolution 0.65 1080p digital micromirror device (DMD) is a spatial light modulator (SLM) that modulates the amplitude, direction, and/or phase of incoming light. The unique capability and value offered by the DLP6500FLQ, including operation at 405nm, makes it well suited to support a wide variety of industrial, medical, and advanced imaging applications. Reliable function and operation of the DLP6500FLQ requires that it be used in conjunction with the DLPC900 digital controller. This dedicated chipset provides full HD resolution at high speeds and can be easily integrated into a variety of end equipment solutions.

#### Device Information<sup>(1)</sup>

PART NUMBER	PACKAGE	BODY SIZE (NOM)
DLP6500	FLQ (203)	40.6 × 31.8 × 6 mm

(1) For all available packages, see the orderable addendum at the end of the datasheet.

#### Simplified Diagram

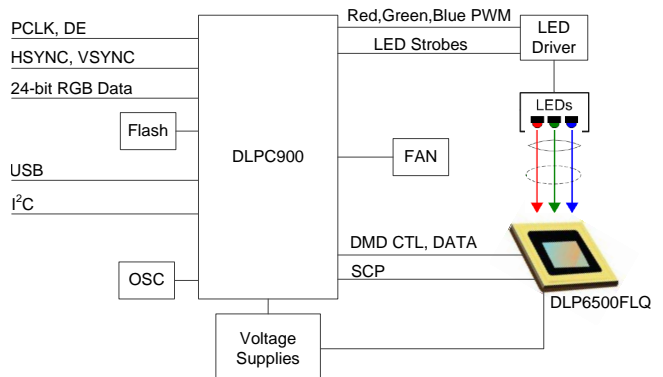

## Table of Contents

<b>1 Features</b> .....	<b>1</b>	7.4 Device Functional Modes.....	<b>28</b>
<b>2 Applications</b> .....	<b>1</b>	7.5 Window Characteristics and Optics .....	<b>28</b>
<b>3 Description</b> .....	<b>1</b>	7.6 Micromirror Array Temperature Calculation.....	<b>29</b>
<b>4 Revision History</b> .....	<b>2</b>	7.7 Micromirror Landed-on/Landed-Off Duty Cycle .....	<b>30</b>
<b>5 Pin Configuration and Functions</b> .....	<b>3</b>	<b>8 Application and Implementation</b> .....	<b>32</b>
<b>6 Specifications</b> .....	<b>9</b>	8.1 Application Information.....	<b>32</b>
6.1 Absolute Maximum Ratings .....	<b>9</b>	8.2 Typical Application .....	<b>32</b>
6.2 Handling Ratings.....	<b>9</b>	<b>9 Power Supply Recommendations</b> .....	<b>33</b>
6.3 Recommended Operating Conditions.....	<b>10</b>	9.1 DMD Power Supply Requirements .....	<b>33</b>
6.4 Thermal Information .....	<b>12</b>	9.2 DMD Power Supply Power-Up Procedure .....	<b>33</b>
6.5 Electrical Characteristics.....	<b>13</b>	9.3 DMD Power Supply Power-Down Procedure .....	<b>33</b>
6.6 Timing Requirements .....	<b>14</b>	<b>10 Layout</b> .....	<b>36</b>
6.7 Typical Characteristics .....	<b>18</b>	10.1 Layout Guidelines .....	<b>36</b>
6.8 System Mounting Interface Loads .....	<b>19</b>	10.2 Layout Example .....	<b>36</b>
6.9 Micromirror Array Physical Characteristics .....	<b>20</b>	<b>11 Device and Documentation Support</b> .....	<b>41</b>
6.10 Micromirror Array Optical Characteristics .....	<b>21</b>	11.1 Device Support.....	<b>41</b>
6.11 Window Characteristics.....	<b>22</b>	11.2 Documentation Support .....	<b>42</b>
6.12 Chipset Component Usage Specification .....	<b>22</b>	11.3 Trademarks .....	<b>42</b>
<b>7 Detailed Description</b> .....	<b>23</b>	11.4 Electrostatic Discharge Caution.....	<b>42</b>
7.1 Overview .....	<b>23</b>	11.5 Glossary .....	<b>42</b>
7.2 Functional Block Diagram .....	<b>24</b>	<b>12 Mechanical, Packaging, and Orderable Information</b> .....	<b>42</b>
7.3 Feature Description.....	<b>25</b>		

## 4 Revision History

DATE	REVISION	NOTES
October 2014	*	Initial release.

## 5 Pin Configuration and Functions

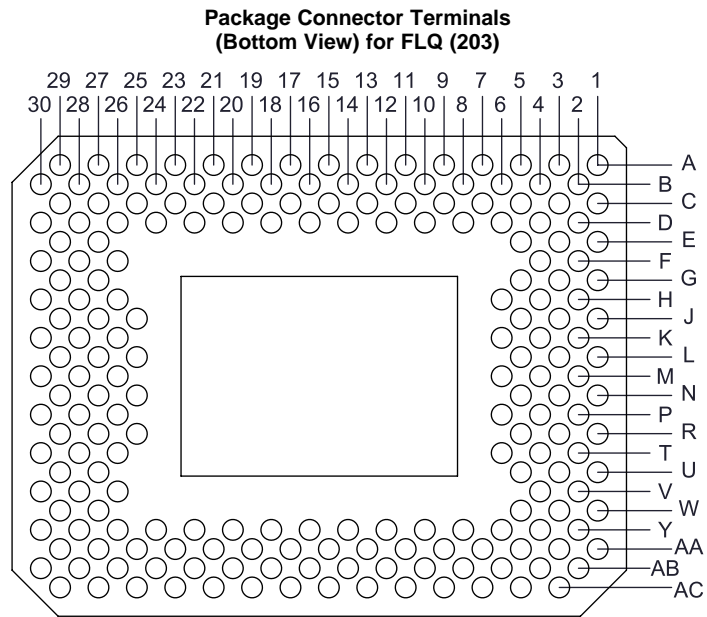

**Pin Functions**

PIN <sup>(1)</sup>		TYPE (I/O/P)	SIGNAL	DATA RATE <sup>(2)</sup>	INTERNAL TERM <sup>(3)</sup>	DESCRIPTION	TRACE (mils) <sup>(4)</sup>
NAME	NO.						
<b>DATA BUS A</b>							
D_AN(0)	B10	Input	LVDS	DDR	Differential	Data, Negative	557.27
D_AN(1)	A13	Input	LVDS	DDR	Differential	Data, Negative	558.46
D_AN(2)	D16	Input	LVDS	DDR	Differential	Data, Negative	556.87
D_AN(3)	C17	Input	LVDS	DDR	Differential	Data, Negative	555.6
D_AN(4)	B18	Input	LVDS	DDR	Differential	Data, Negative	555.33
D_AN(5)	A17	Input	LVDS	DDR	Differential	Data, Negative	555.76
D_AN(6)	A25	Input	LVDS	DDR	Differential	Data, Negative	556.47
D_AN(7)	D22	Input	LVDS	DDR	Differential	Data, Negative	555.79
D_AN(8)	C29	Input	LVDS	DDR	Differential	Data, Negative	556.54
D_AN(9)	D28	Input	LVDS	DDR	Differential	Data, Negative	555.23
D_AN(10)	E27	Input	LVDS	DDR	Differential	Data, Negative	555.55
D_AN(11)	F26	Input	LVDS	DDR	Differential	Data, Negative	556.48
D_AN(12)	G29	Input	LVDS	DDR	Differential	Data, Negative	555.91
D_AN(13)	H28	Input	LVDS	DDR	Differential	Data, Negative	556.38
D_AN(14)	J27	Input	LVDS	DDR	Differential	Data, Negative	559.01
D_AN(15)	K26	Input	LVDS	DDR	Differential	Data, Negative	556.11
D_AP(0)	B12	Input	LVDS	DDR	Differential	Data, Positive	555.99
D_AP(1)	A11	Input	LVDS	DDR	Differential	Data, Positive	556.02
D_AP(2)	D14	Input	LVDS	DDR	Differential	Data, Positive	556.31
D_AP(3)	C15	Input	LVDS	DDR	Differential	Data, Positive	555.88
D_AP(4)	B16	Input	LVDS	DDR	Differential	Data, Positive	556.08
D_AP(5)	A19	Input	LVDS	DDR	Differential	Data, Positive	556.33
D_AP(6)	A23	Input	LVDS	DDR	Differential	Data, Positive	556.13
D_AP(7)	D20	Input	LVDS	DDR	Differential	Data, Positive	555.21
D_AP(8)	A29	Input	LVDS	DDR	Differential	Data, Positive	555.58
D_AP(9)	B28	Input	LVDS	DDR	Differential	Data, Positive	555.39
D_AP(10)	C27	Input	LVDS	DDR	Differential	Data, Positive	556.11
D_AP(11)	D26	Input	LVDS	DDR	Differential	Data, Positive	555.88
D_AP(12)	F30	Input	LVDS	DDR	Differential	Data, Positive	556.58
D_AP(13)	H30	Input	LVDS	DDR	Differential	Data, Positive	556.3
D_AP(14)	J29	Input	LVDS	DDR	Differential	Data, Positive	557.67
D_AP(15)	K28	Input	LVDS	DDR	Differential	Data, Positive	555.32
<b>DATA BUS B</b>							
D_BN(0)	AB10	Input	LVDS	DDR	Differential	Data, Negative	552.46
D_BN(1)	AC13	Input	LVDS	DDR	Differential	Data, Negative	556.99
D_BN(2)	Y16	Input	LVDS	DDR	Differential	Data, Negative	545.06
D_BN(3)	AA17	Input	LVDS	DDR	Differential	Data, Negative	555.44
D_BN(4)	AB18	Input	LVDS	DDR	Differential	Data, Negative	556.34
D_BN(5)	AC17	Input	LVDS	DDR	Differential	Data, Negative	547.1
D_BN(6)	AC25	Input	LVDS	DDR	Differential	Data, Negative	557.92
D_BN(7)	Y22	Input	LVDS	DDR	Differential	Data, Negative	544.03

(1) The following power supplies are required to operate the DMD: VCC, VCCI, VOFFSET, VBIAS, and VRESET. VSS must also be connected.

(2) DDR = Double Data Rate.  
SDR = Single Data Rate.

Refer to the [Timing Requirements](#) for specifications and relationships.

(3) Internal term = CMOS level internal termination.

Refer to [Recommended Operating Conditions](#) for differential termination specification.

(4) Dielectric Constant for the DMD Type A ceramic package is approximately 9.6.

For the package trace lengths shown:

Propagation Speed =  $11.8 / \sqrt{9.6} = 3.808$  in/ns.

Propagation Delay =  $0.262$  ns/in =  $262$  ps/in =  $10.315$  ps/mm.

**Pin Functions (continued)**

PIN <sup>(1)</sup>		TYPE (I/O/P)	SIGNAL	DATA RATE <sup>(2)</sup>	INTERNAL TERM <sup>(3)</sup>	DESCRIPTION	TRACE (mils) <sup>(4)</sup>
NAME	NO.						
D_BN(8)	AA29	Input	LVDS	DDR	Differential	Data, Negative	555.9
D_BN(9)	Y28	Input	LVDS	DDR	Differential	Data, Negative	555.42
D_BN(10)	W27	Input	LVDS	DDR	Differential	Data, Negative	556.26
D_BN(11)	V26	Input	LVDS	DDR	Differential	Data, Negative	555.52
D_BN(12)	T30	Input	LVDS	DDR	Differential	Data, Negative	556
D_BN(13)	R29	Input	LVDS	DDR	Differential	Data, Negative	557.17
D_BN(14)	R27	Input	LVDS	DDR	Differential	Data, Negative	555.25
D_BN(15)	N27	Input	LVDS	DDR	Differential	Data, Negative	555.19
D_BP(0)	AB12	Input	LVDS	DDR	Differential	Data, Positive	551.93
D_BP(1)	AC11	Input	LVDS	DDR	Differential	Data, Positive	557.1
D_BP(2)	Y14	Input	LVDS	DDR	Differential	Data, Positive	544.38
D_BP(3)	AA15	Input	LVDS	DDR	Differential	Data, Positive	555.98
D_BP(4)	AB16	Input	LVDS	DDR	Differential	Data, Positive	555.56
D_BP(5)	AC19	Input	LVDS	DDR	Differential	Data, Positive	547.17
D_BP(6)	AC23	Input	LVDS	DDR	Differential	Data, Positive	556.47
D_BP(7)	Y20	Input	LVDS	DDR	Differential	Data, Positive	543.25
D_BP(8)	AC29	Input	LVDS	DDR	Differential	Data, Positive	555.71
D_BP(9)	AB28	Input	LVDS	DDR	Differential	Data, Positive	556.32
D_BP(10)	AA27	Input	LVDS	DDR	Differential	Data, Positive	555.35
D_BP(11)	Y26	Input	LVDS	DDR	Differential	Data, Positive	555.65
D_BP(12)	U29	Input	LVDS	DDR	Differential	Data, Positive	555.28
D_BP(13)	T28	Input	LVDS	DDR	Differential	Data, Positive	557.25
D_BP(14)	P28	Input	LVDS	DDR	Differential	Data, Positive	555.83
D_BP(15)	P26	Input	LVDS	DDR	Differential	Data, Positive	556.67
<b>SERIAL CONTROL</b>							
SCTRL_AN	C21	Input	LVDS	DDR	Differential	Serial Control, Negative	555.14
SCTRL_BN	AA21	Input	LVDS	DDR	Differential	Serial Control, Negative	555.14
SCTRL_AP	C23	Input	LVDS	DDR	Differential	Serial Control, Positive	555.13
SCTRL_BP	AA23	Input	LVDS	DDR	Differential	Serial Control, Positive	555.13
<b>CLOCKS</b>							
DCLK_AN	B22	Input	LVDS		Differential	Clock Negative	555.12
DCLK_BN	AB22	Input	LVDS		Differential	Clock Negative	555.12
DCLK_AP	B24	Input	LVDS		Differential	Clock Positive	555.13
DCLK_BP	AB24	Input	LVDS		Differential	Clock Positive	555.12
<b>SERIAL COMMUNICATIONS PORT (SCP)</b>							
SCP_DO	B2	Output	LVC MOS	SDR		Serial Communications Port Output	525.78
SCP_DI	F4	Input	LVC MOS	SDR	Pull-Down	Serial Communications Port Data Input	509.96
SCP_CLK	E3	Input	LVC MOS		Pull-Down	Serial Communications Port Clock	403.93
SCP_ENZ	D4	Input	LVC MOS		Pull-Down	Active-low Serial Communications Port Enable	464.17
<b>MICROMIRROR RESET CONTROL</b>							
RESET_ADDR(0)	C5	Input	LVC MOS		Pull-Down	Reset Driver Address Select	1088.3
RESET_ADDR(1)	E5	Input	LVC MOS		Pull-Down	Reset Driver Address Select	979.26
RESET_ADDR(2)	G5	Input	LVC MOS		Pull-Down	Reset Driver Address Select	900.45
RESET_ADDR(3)	AC3	Input	LVC MOS		Pull-Down	Reset Driver Address Select	658.56
RESET_MODE(0)	D8	Input	LVC MOS		Pull-Down	Reset Driver Mode Select	1012.52
RESET_MODE(1)	C11	Input	LVC MOS		Pull-Down	Reset Driver Mode Select	789.83
RESET_SEL(0)	T4	Input	LVC MOS		Pull-Down	Reset Driver Level Select	539.64
RESET_SEL(1)	U5	Input	LVC MOS		Pull-Down	Reset Driver Level Select	400.3
RESET_STROBE	V2	Input	LVC MOS		Pull-Down	Reset Address, Mode, & Level latched on rising-edge	446.34

**Pin Functions (continued)**

PIN <sup>(1)</sup>		TYPE (I/O/P)	SIGNAL	DATA RATE <sup>(2)</sup>	INTERNAL TERM <sup>(3)</sup>	DESCRIPTION	TRACE (mils) <sup>(4)</sup>
NAME	NO.						
<b>ENABLES &amp; INTERRUPTS</b>							
PWRDNZ	C3	Input	LVC MOS		Pull-Down	Active-low Device Reset	390.76
RESET_OEZ	W1	Input	LVC MOS		Pull-Down	Active-low output enable for DMD reset driver circuits	513.87
RESETZ	G3	Input	LVC MOS		Pull-Down	Active-low sets Reset circuits in known VOFFSET state	941.63
RESET_IRQZ	T6	Output	LVC MOS			Active-low, output interrupt to ASIC	403.34
<b>VOLTAGE REGULATOR MONITORING</b>							
PG_BIAS	AA11	Input	LVC MOS		Pull-Up	Active-low fault from external VBIAS regulator	858.86
PG_OFFSET	Y10	Input	LVC MOS		Pull-Up	Active-low fault from external VOFFSET regulator	822.06
PG_RESET	V4	Input	LVC MOS		Pull-Up	Active-low fault from external VRESET regulator	1186.98
EN_BIAS	D12	Output	LVC MOS			Active-high enable for external VBIAS regulator	167.53
EN_OFFSET	AB8	Output	LVC MOS			Active-high enable for external VOFFSET regulator	961.04
EN_RESET	H2	Output	LVC MOS			Active-high enable for external VRESET regulator	566.05
<b>LEAVE PIN UNCONNECTED</b>							
MBRST(0)	P2	Output	Analog		Pull-Down	For proper DMD operation, do not connect	1167.69
MBRST(1)	AB4	Output	Analog		Pull-Down	For proper DMD operation, do not connect	1348.04
MBRST(2)	AA7	Output	Analog		Pull-Down	For proper DMD operation, do not connect	1240.35
MBRST(3)	N3	Output	Analog		Pull-Down	For proper DMD operation, do not connect	1030.51
MBRST(4)	M4	Output	Analog		Pull-Down	For proper DMD operation, do not connect	870.63
MBRST(5)	AB6	Output	Analog		Pull-Down	For proper DMD operation, do not connect	1267.73
MBRST(6)	AA5	Output	Analog		Pull-Down	For proper DMD operation, do not connect	1391.22
MBRST(7)	L3	Output	Analog		Pull-Down	For proper DMD operation, do not connect	1064.01
MBRST(8)	Y6	Output	Analog		Pull-Down	For proper DMD operation, do not connect	552.89
MBRST(9)	K4	Output	Analog		Pull-Down	For proper DMD operation, do not connect	992.63
MBRST(10)	L5	Output	Analog		Pull-Down	For proper DMD operation, do not connect	1063.13
MBRST(11)	AC5	Output	Analog		Pull-Down	For proper DMD operation, do not connect	641.44
MBRST(12)	Y8	Output	Analog		Pull-Down	For proper DMD operation, do not connect	428.07
MBRST(13)	J5	Output	Analog		Pull-Down	For proper DMD operation, do not connect	962.91
MBRST(14)	K6	Output	Analog		Pull-Down	For proper DMD operation, do not connect	1093.63
MBRST(15)	AC7	Output	Analog		Pull-Down	For proper DMD operation, do not connect	577.13
<b>LEAVE PIN UNCONNECTED</b>							
RESERVED_PFE	AA1	Input	LVC MOS		Pull-Down	For proper DMD operation, do not connect	1293.6
RESERVED_TM	B6	Input	LVC MOS		Pull-Down	For proper DMD operation, do not connect	365.64
RESERVED_XI1	D2	Input	LVC MOS		Pull-Down	For proper DMD operation, do not connect	689.96
RESERVED_TP0	Y2	Input	Analog			For proper DMD operation, do not connect	667.66
RESERVED_TP1	P6	Input	Analog			For proper DMD operation, do not connect	623.99
RESERVED_TP2	W3	Input	Analog			For proper DMD operation, do not connect	564.35
<b>LEAVE PIN UNCONNECTED</b>							
RESERVED_BA	U3	Output	LVC MOS			For proper DMD operation, do not connect	684.44
RESERVED_BB	C9	Output	LVC MOS			For proper DMD operation, do not connect	223.73
RESERVED_TS	D10	Output	LVC MOS			For proper DMD operation, do not connect	90.87
<b>LEAVE PIN UNCONNECTED</b>							
NO CONNECT	H6					For proper DMD operation, do not connect	

NAME <sup>(1)</sup>	PIN			TYPE (I/O/P)	SIGNAL	DESCRIPTION
	NO.	NO.	NO.			
VBIAS	N5	P4	R3	Power	Analog	Supply voltage for positive Bias level of Micromirror reset signal.
VBIAS	R5			Power	Analog	Supply voltage for positive Bias level of Micromirror reset signal.
VOFFSET	G1	J1	L1	Power	Analog	Supply voltage for HVCMOS logic. Supply voltage for stepped high voltage at Micromirror address electrodes. Supply voltage positive Offset level of Micromirror reset signal.
VOFFSET	N1	R1		Power	Analog	
VRESET	A3	A5	B4	Power	Analog	Power supply for negative reset level of mirror reset signal
VRESET	C7			Power	Analog	Power supply for negative reset level of mirror reset signal
VCC	A7	A15	C1	Power	Analog	Supply voltage for LVCMOS core logic.
VCC	E1	U1	AB2	Power	Analog	Supply voltage for normal high level at Micromirror address electrodes.
VCC	AC9	AC15		Power	Analog	Supply voltage for positive Offset level of Micromirror reset signal during Power Down sequence.
VCCI	A21	A27	D30	Power	Analog	Power supply for LVDS Interface
VCCI	M30	Y30	AC21	Power	Analog	Power supply for LVDS Interface
VCCI	AC27			Power	Analog	Power supply for LVDS Interface
VSS	A1	A9	B8	Power	Analog	Device Ground. Common return for all power.
VSS	B14	B20	B26	Power	Analog	Device Ground. Common return for all power.
VSS	B30	C13	C19	Power	Analog	Device Ground. Common return for all power.
VSS	C25	D6	D18	Power	Analog	Device Ground. Common return for all power.
VSS	D24	E29	F2	Power	Analog	Device Ground. Common return for all power.
VSS	F28	G27	H4	Power	Analog	Device Ground. Common return for all power.
VSS	H26	J3	J25	Power	Analog	Device Ground. Common return for all power.
VSS	K2	K30	L25	Power	Analog	Device Ground. Common return for all power.
VSS	L27	L29	M2	Power	Analog	Device Ground. Common return for all power.
VSS	M6	M26	M28	Power	Analog	Device Ground. Common return for all power.
VSS	N25	N29	P30	Power	Analog	Device Ground. Common return for all power.
VSS	R25	T2	T26	Power	Analog	Device Ground. Common return for all power.
VSS	U27	V28	V30	Power	Analog	Device Ground. Common return for all power.
VSS	W5	W29	Y4	Power	Analog	Device Ground. Common return for all power.

(1) The following power supplies are required to operate the DMD: VCC, VCCI, VOFFSET, VBIAS, and VRESET. VSS must also be connected.

**DLP6500FLQ**

DLPS040 – OCTOBER 2014

[www.ti.com](http://www.ti.com)

NAME <sup>(1)</sup>	PIN			TYPE (I/O/P)	SIGNAL	DESCRIPTION
	NO.	NO.	NO.			
VSS	Y12	Y18	Y24	Power	Analog	Device Ground. Common return for all power.
VSS	AA3	AA9	AA13	Power	Analog	Device Ground. Common return for all power.
VSS	AA19	AA25	AB14	Power	Analog	Device Ground. Common return for all power.
VSS	AB20	AB26	AB30	Power	Analog	Device Ground. Common return for all power.



## 6 Specifications

### 6.1 Absolute Maximum Ratings

over operating free-air temperature (unless otherwise noted) <sup>(1)</sup>

SUPPLY VOLTAGES		MIN	MAX	UNIT
VCC	Supply voltage for LVCMOS core logic <sup>(2)</sup>	-0.5	4	V
VCCI	Supply voltage for LVDS receivers <sup>(2)</sup>	-0.5	4	V
VOFFSET	Supply voltage for HVCMOS and micromirror electrode <sup>(2) (3)</sup>	-0.5	9	V
VBIAS	Supply voltage for micromirror electrode <sup>(2)</sup>	-0.5	17	V
VRESET	Supply voltage for micromirror electrode <sup>(2)</sup>	-11	0.5	V
VCC – VCCI	Supply voltage delta (absolute value) <sup>(4)</sup>		0.3	V
VBIAS – VOFFSET	Supply voltage delta (absolute value) <sup>(5)</sup>		8.75	V
INPUT VOLTAGES				
	Input voltage for all other LVCMOS input pins <sup>(2)</sup>	-0.5	VCC + 0.3	V
	Input voltage for all other LVDS input pins <sup>(2)</sup>	-0.5	VCCI + 0.3	V
V <sub>ID</sub>	Input differential voltage (absolute value) <sup>(2) (6)</sup>		700	mV
I <sub>ID</sub>	Input differential current <sup>(7)</sup>		7	mA
CLOCKS				
f <sub>clock</sub>	Clock frequency for LVDS interface, DCLK_A		460	MHz
	Clock frequency for LVDS interface, DCLK_B		460	MHz
	Clock frequency for LVDS interface, DCLK_C		460	MHz
	Clock frequency for LVDS interface, DCLK_D		460	MHz
ENVIRONMENTAL				
T <sub>CASE</sub>	Case temperature: operational <sup>(8)(9)</sup>	0	70	°C
	Case temperature: non-operational <sup>(9)</sup>	-40	80	°C
	Differential temperature <sup>(8)</sup>		10	°C
	Operating relative humidity ( non-condensing )	0	95%	

- (1) Stresses beyond those listed under Absolute Maximum Ratings may cause permanent damage to the device. These are stress ratings only, and functional operation of the device is not implied at these or any other conditions beyond those indicated under [Recommended Operating Conditions](#). Exposure above [Recommended Operating Conditions](#) for extended periods may affect device reliability.
- (2) All voltages are referenced to common ground VSS. Supply voltages VCC, VCCI, VOFFSET, VBIAS, and VRESET are all required for proper DMD operation. VSS must also be connected.
- (3) VOFFSET supply transients must fall within specified voltages.
- (4) To prevent excess current, the supply voltage delta |VCCI – VCC| must be less than specified limit.
- (5) To prevent excess current, the supply voltage delta |VBIAS – VOFFSET| must be less than specified limit. Refer to [Power Supply Recommendations](#) for additional information.
- (6) This maximum LVDS input voltage rating applies when each input of a differential pair is at the same voltage potential.
- (7) LVDS differential inputs must not exceed the specified limit or damage may result to the internal termination resistors.
- (8) Exposure of the DMD simultaneously to any combination of the maximum operating conditions for case temperature, differential temperature, or illumination power density will reduce device lifetime. Refer to [Handling Ratings](#).
- (9) DMD Temperature is the worst-case of any thermal test point in [Figure 15](#), or the active array as calculated by the Micromirror Array Temperature Calculation.

### 6.2 Handling Ratings

		MIN	MAX	UNIT
T <sub>stg</sub>	Storage temperature range (non-operating) <sup>(1)(2)(3)</sup>	-40	80	°C
	Storage humidity, non – condensing <sup>(1)(2)(3)</sup>	0%	95%	RH
V <sub>(ESD)</sub>	Electrostatic discharge	All pins, human body model (HBM), per ANSI/ESDA/JEDEC JS-001 <sup>(4)</sup>		2000 V

- (1) Simultaneous exposure to high storage temperature and high storage humidity may affect device reliability.
- (2) As a best practice, TI recommends storing the DMD in a temperature and humidity controlled environment.
- (3) Optimal, long-term performance of the DMD can be affected by ambient storage temperature and ambient storage humidity.
- (4) JEDEC document JEP155 states that 500 V HBM allows safe manufacturing with a standard ESD control process.

### 6.3 Recommended Operating Conditions

over operating free-air temperature range (unless otherwise noted)

		MIN	NOM	MAX	UNIT
<b>SUPPLY VOLTAGES<sup>(1)(2)</sup></b>					
VCC	Supply voltage for LVCMOS core logic	3.0	3.3	3.6	V
VCCI	Supply voltage for LVDS receivers	3.0	3.3	3.6	V
VOFFSET	Supply voltage for HVCMOS and micromirror electrodes <sup>(3)</sup>	8.25	8.5	8.75	V
VBIAS	Supply voltage for micromirror electrodes	15.5	16	16.5	V
VRESET	Mirror electrode voltage	−9.5	−10	−10.5	V
VCCI−VCC	Supply voltage delta (absolute value) <sup>(4)</sup>			0.3	V
VBIAS−VOFFSET	Supply voltage delta (absolute value) <sup>(5)</sup>			8.75	V
<b>LVCMOS PINS</b>					
V <sub>IH</sub>	High level Input voltage <sup>(6)</sup>	1.7	2.5	VCC + 0.3	V
V <sub>IL</sub>	Low level Input voltage <sup>(6)</sup>	−0.3		0.7	V
I <sub>OH</sub>	High level output current at V <sub>OH</sub> = 2.4 V			−20	mA
I <sub>OL</sub>	Low level output current at V <sub>OL</sub> = 0.4 V			15	mA
T <sub>PWRDNZ</sub>	PWRDNZ pulse width <sup>(7)</sup>	10			ns
<b>SCP INTERFACE<sup>(5)</sup></b>					
f <sub>clock</sub>	SCP clock frequency <sup>(8)</sup>			500	kHz
t <sub>SCP_SKEW</sub>	Time between valid SCPDI and rising edge of SCPCLK <sup>(9)</sup>	−800		800	ns
t <sub>SCP_DELAY</sub>	Time between valid SCPDO and rising edge of SCPCLK <sup>(9)</sup>			700	ns
t <sub>SCP_BYTE_INTERVAL_</sub>	Time between consecutive bytes	1			μs
t <sub>SCP_NEG_ENZ</sub>	Time between falling edge of SCPENZ and the first rising edge of SCPCLK	30			ns
t <sub>SCP_PW_ENZ</sub>	SCPENZ inactive pulse width (high level)	1			μs
t <sub>SCP_OUT_EN</sub>	Time required for SCP output buffer to recover after SCPENZ (from tri-state)			1.5	ns
f <sub>clock</sub>	SCP circuit clock oscillator frequency <sup>(10)</sup>	9.6		11.1	MHz
<b>LVDS INTERFACE</b>					
f <sub>clock</sub>	Clock frequency DCLK			400	MHz
V <sub>ID</sub>	Input differential voltage (absolute value) <sup>(11)</sup>	100	400	600	mV
V <sub>CM</sub>	Common mode <sup>(11)</sup>		1200		mV
V <sub>LVDS</sub>	LVDS voltage <sup>(11)</sup>	0		2000	mV
t <sub>LVDS_RSTZ</sub>	Time required for LVDS receivers to recover from PWRDNZ			10	ns
Z <sub>IN</sub>	Internal differential termination resistance	95		105	Ω
Z <sub>LINE</sub>	Line differential impedance (PWB/trace)	90	100	110	Ω

(1) Supply voltages VCC, VCCI, VOFFSET, VBIAS, and VRESET are all required for proper DMD operation. VSS must also be connected.

(2) All voltages are referenced to common ground VSS.

(3) VOFFSET supply transients must fall within specified max voltages.

(4) To prevent excess current, the supply voltage delta |VCCI − VCC| must be less than specified limit.

(5) To prevent excess current, the supply voltage delta |VBIAS − VOFFSET| must be less than specified limit. Refer to [Power Supply Recommendations](#) for additional information.

(6) Tester Conditions for VIH and VIL:

Frequency = 60MHz. Maximum Rise Time = 2.5ns @ (20% to 80%)

Frequency = 60MHz. Maximum Fall Time = 2.5ns @ (80% to 20%)

(7) PWRDNZ input pin resets the SCP and disables the LVDS receivers. PWRDNZ input pin overrides SCPENZ input pin and tri-states the SCPDO output pin.

(8) The SCP clock is a gated clock. Duty cycle shall be 50% ± 10%. SCP parameter is related to the frequency of DCLK.

(9) Refer to [Figure 3](#).

(10) SCP internal oscillator is specified to operate all SCP registers. For all SCP operations, DCLK is required.

(11) Refer to [Figure 4](#), [Figure 5](#), and [Figure 6](#).

## Recommended Operating Conditions (continued)

over operating free-air temperature range (unless otherwise noted)

		MIN	NOM	MAX	UNIT
<b>ENVIRONMENTAL</b> <sup>(12)</sup>	<b>For Illumination Source between 420 and 700 nm</b>				
T <sub>DMD</sub>	DMD temperature – operational <sup>(13)(14)</sup>	10		40 to 70 <sup>(14)</sup>	°C
T <sub>WINDOW</sub>	Window temperature – operational			70	°C
T <sub>GRADIENT</sub>	Device temperature gradient – operational <sup>(15)</sup>			10	°C
ILL <sub>VIS</sub>	Illumination, wavelengths between 420 and 700 nm			Thermally Limited <sup>(16)</sup>	mW /cm <sup>2</sup>
<b>ENVIRONMENTAL</b> <sup>(12)</sup>	<b>For Illumination Source between 400 and 420 nm</b>				
T <sub>DMD</sub>	DMD temperature – operational <sup>(13)(14)</sup>	20		30 <sup>(14)</sup>	°C
T <sub>GRADIENT</sub>	Device temperature gradient – operational <sup>(15)</sup>			10	°C
ILL <sub>VIS</sub>	Illumination, wavelengths between 400 and 420 nm			2.5	W/cm <sup>2</sup>
<b>ENVIRONMENTAL</b> <sup>(12)</sup>	<b>For Illumination Source &lt;420 and &gt;700 nm</b>				
T <sub>DMD</sub>	DMD temperature – operational <sup>(13)(14)</sup>	10		40 to 70 <sup>(14)</sup>	°C
T <sub>WINDOW</sub>	Window temperature – operational			70	°C
T <sub>GRADIENT</sub>	Device temperature gradient – operational <sup>(15)</sup>			10	°C
ILL <sub>UV</sub>	Illumination, wavelength < 400 nm			0.68	mW /cm <sup>2</sup>
ILL <sub>IR</sub>	Illumination, wavelength > 700 nm			10	mW /cm <sup>2</sup>

(12) Optimal, long-term performance and optical efficiency of the Digital Micromirror Device (DMD) can be affected by various application parameters, including illumination spectrum, illumination power density, micromirror landed duty-cycle, ambient temperature (storage and operating), DMD temperature, ambient humidity (storage and operating), and power on or off duty cycle. TI recommends that application-specific effects be considered as early as possible in the design cycle.

(13) DMD Temperature is the worst-case of any thermal test point in [Figure 15](#), or the active array as calculated by the [Micromirror Array Temperature Calculation](#).

(14) Per [Figure 1](#), the maximum operational case temperature should be derated based on the micromirror landed duty cycle that the DMD experiences in the end application. Refer to [Micromirror Landed-on/Landed-Off Duty Cycle](#) for a definition of micromirror landed duty cycle.

(15) As measured between any two points on the exterior of the package, or as predicted between any two points inside the micromirror array cavity. Refer to [Thermal Information](#) and [Micromirror Array Temperature Calculation](#).

(16) Refer to [Thermal Information](#) and [Micromirror Array Temperature Calculation](#).

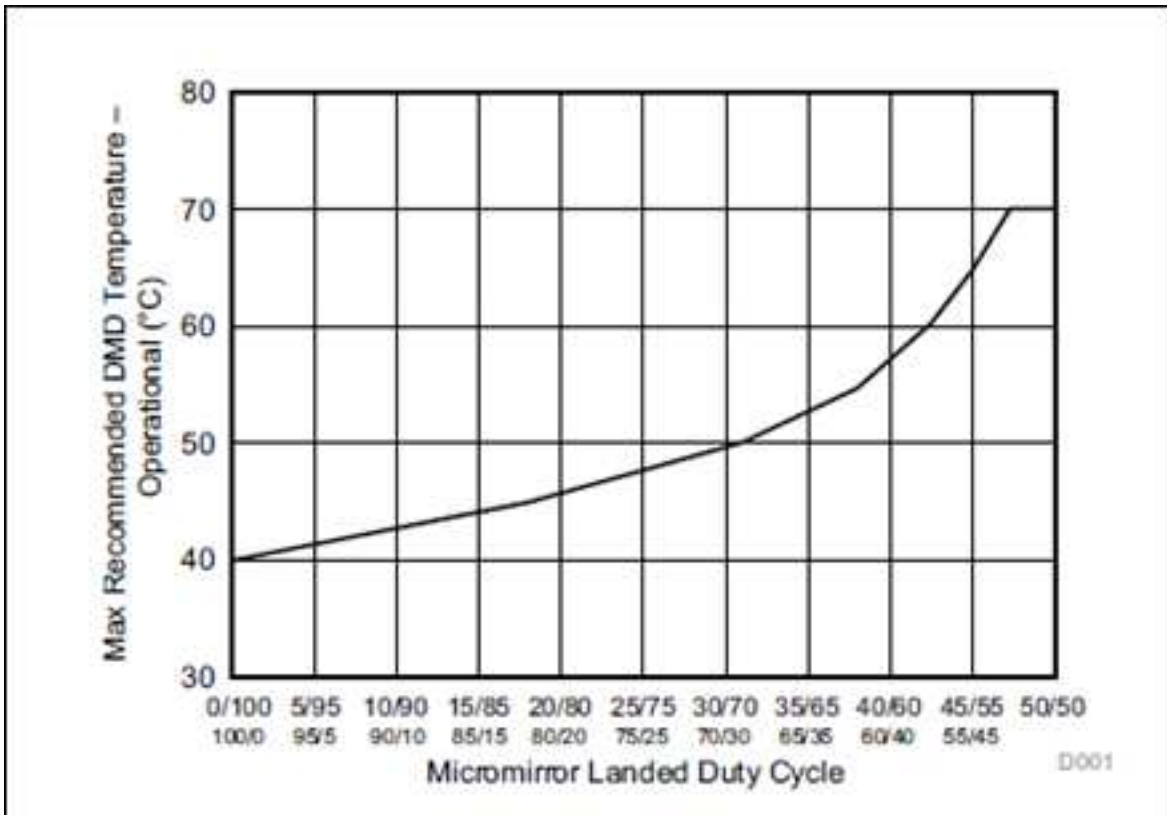

Figure 1. Max Recommended DMD Temperature – Derating Curve

### 6.4 Thermal Information

THERMAL METRIC <sup>(1)</sup>	MIN	DLP6500FLQ FLQ (203)	MAX	UNIT
Active Area to Case Ceramic Thermal resistance <sup>(1)</sup>			0.7	°C/W

- (1) The DMD is designed to conduct absorbed and dissipated heat to the back of the package where it can be removed by an appropriate heat sink. The heat sink and cooling system must be capable of maintaining the package within the temperature range specified in the [Recommended Operating Conditions](#). The total heat load on the DMD is largely driven by the incident light absorbed by the active area; although other contributions include light energy absorbed by the window aperture and electrical power dissipation of the array. Optical systems should be designed to minimize the light energy falling outside the window clear aperture since any additional thermal load in this area can significantly degrade the reliability of the device.

## 6.5 Electrical Characteristics

over recommended operating free-air temperature range (unless otherwise noted)

PARAMETER	DESCRIPTION	TEST CONDITIONS <sup>(1)</sup>	MIN	TYP	MAX	UNIT
V <sub>OH</sub>	High-level output voltage	VCC = 3 V, I <sub>OH</sub> = –20 mA	2.4			V
V <sub>OL</sub>	Low level output voltage	VCC = 3.6 V, I <sub>OL</sub> = 15 mA			0.4	V
I <sub>IH</sub>	High-level input current <sup>(2)(3)</sup>	VCC = 3.6 V, V <sub>I</sub> = VCC			250	μA
I <sub>IL</sub>	Low level input current	VCC = 3.6 V, V <sub>I</sub> = 0	–250			μA
I <sub>OZ</sub>	High-impedance output current	VCC = 3.6 V			10	μA
<b>CURRENT</b>						
I <sub>CC</sub>	Supply current <sup>(4)</sup>	VCC = 3.6 V			1076	mA
I <sub>CCI</sub>	Supply current <sup>(4)</sup>	VCCI = 3.6 V			518	
I <sub>OFFSET</sub>	Supply current <sup>(5)</sup>	V <sub>OFFSET</sub> = 8.75 V			4	mA
I <sub>BIAS</sub>	Supply current <sup>(5)</sup>	V <sub>BIAS</sub> = 16.5 V			14	
I <sub>RESET</sub>	Supply current	V <sub>RESET</sub> = –10.5 V			11	mA
I <sub>TOTAL</sub>	Supply current	Total Sum			1623	
<b>POWER</b>						
P <sub>CC</sub>	Supply power dissipation	VCC = 3.6 V			3874	mW
P <sub>CCI</sub>		VCCI = 3.6 V			1865	
P <sub>OFFSET</sub>		V <sub>OFFSET</sub> = 8.75 V			35	
P <sub>BIAS</sub>		V <sub>BIAS</sub> = 16.5 V			231	
P <sub>RESET</sub>		V <sub>RESET</sub> = –10.5 V			116	
P <sub>TOTAL</sub>	Supply power dissipation <sup>(6)</sup>	Total Sum			6300	
<b>CAPACITANCE</b>						
C <sub>I</sub>	Input capacitance	f = 1 MHz			10	pF
C <sub>O</sub>	Output capacitance	f = 1 MHz			10	pF
C <sub>M</sub>	Reset group capacitance MBRST(14:0)	f = 1 MHz; 1920 × 72 micromirrors	330		390	pF

- (1) All voltages are referenced to common ground VSS. Supply voltages VCC, VCCI, VOFFSET, VBIAS, and VRESET are all required for proper DMD operation. VSS must also be connected.
- (2) Applies to LVCMOS input pins only. Does not apply to LVDS pins and MBRST pins.
- (3) LVCMOS input pins utilize an internal 18000 Ω passive resistor for pull-up and pull-down configurations. Refer to [Pin Configuration and Functions](#) to determine pull-up or pull-down configuration used.
- (4) To prevent excess current, the supply voltage delta |VCCI – VCC| must be less than specified limit.
- (5) To prevent excess current, the supply voltage delta |VBIAS – VOFFSET| must be less than specified limit.
- (6) Total power on the active micromirror array is the sum of the electrical power dissipation and the absorbed power from the illumination source. See the [Micromirror Array Temperature Calculation](#).

## 6.6 Timing Requirements

Over *Recommended Operating Conditions* unless otherwise noted.

DESCRIPTION <sup>(1)</sup>			MIN	TYP	MAX	UNIT
<b>SCP INTERFACE<sup>(2)</sup></b>						
$t_r$	Rise time	20% to 80%			200	ns
$t_f$	Fall time	80% to 20%			200	ns
<b>LVDS INTERFACE<sup>(2)</sup></b>						
$t_r$	Rise time	20% to 80%	100		400	ps
$t_f$	Fall time	80% to 20%	100		400	ps
<b>LVDS CLOCKS<sup>(3)</sup></b>						
$t_c$	Cycle time	DCLK_A, 50% to 50%	2.5			ns
		DCLK_B, 50% to 50%	2.5			
$t_w$	Pulse duration	DCLK_A, 50% to 50%	1.19	1.25		ns
		DCLK_B, 50% to 50%	1.19	1.25		
<b>LVDS INTERFACE<sup>(3)</sup></b>						
$t_{su}$	Setup time	D_A(15:0) before rising or falling edge of DCLK_A	0.2			ns
		D_B(15:0) before rising or falling edge of DCLK_B	0.2			
$t_{su}$	Setup time	SCTRL_A before rising or falling edge of DCLK_A	0.2			ns
		SCTRL_B before rising or falling edge of DCLK_B	0.2			
$t_h$	Hold time	D_A(15:0) after rising or falling edge of DCLK_A	0.5			ns
		D_B(15:0) after rising or falling edge of DCLK_B	0.5			
$t_h$	Hold time	SCTRL_A after rising or falling edge of DCLK_A	0.5			ns
		SCTRL_B after rising or falling edge of DCLK_B	0.5			
<b>LVDS INTERFACE<sup>(4)</sup></b>						
$t_{skew}$	Skew time	Channel B relative to Channel A	-1.25		1.25	ns
			Channel A includes the following LVDS pairs: DCLK_AP and DCLK_AN SCTRL_AP and SCTRL_AN D_AP(15:0) and D_AN(15:0) Channel B includes the following LVDS pairs: DCLK_BP and DCLK_BN SCTRL_BP and SCTRL_BN D_BP(15:0) and D_BN(15:0)			

(1) Refer to *Pin Configuration and Functions* for pin details.

(2) Refer to *Figure 7*

(3) Refer to *Figure 8*

(4) Refer to *Figure 9*

### Timing Diagrams

The data sheet provides timing at the device pin. For output timing analysis, the tester pin electronics and its transmission line effects must be taken into account. *Figure 2* shows an equivalent test load circuit for the output under test. The load capacitance value stated is only for characterization and measurement of AC timing signals. This load capacitance value does not indicate the maximum load the device is capable of driving.

Timing reference loads are not intended as a precise representation of any particular system environment or depiction of the actual load presented by a production test. System designers should use IBIS or other simulation tools to correlate the timing reference load to a system environment. Refer to the *Application and Implementation* section.

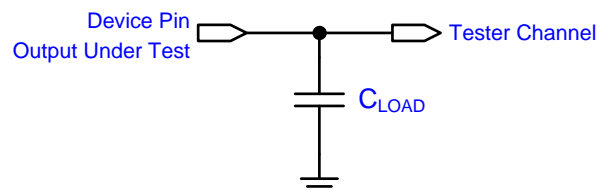

**Figure 2. Test Load Circuit**

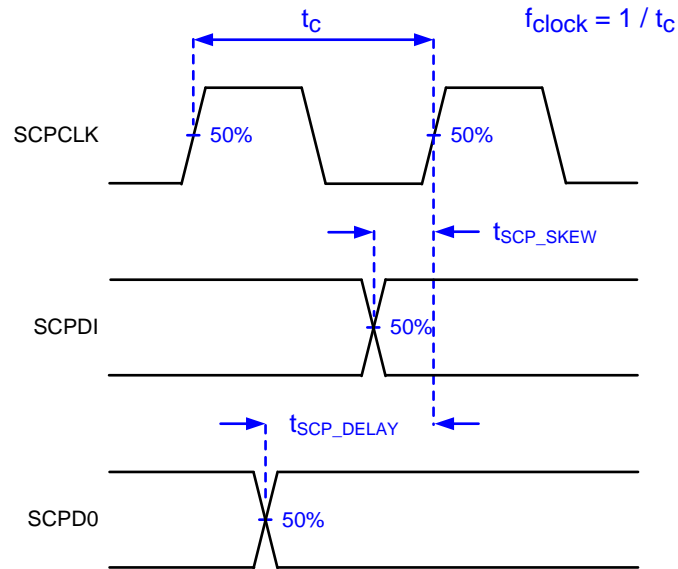

Not to scale.

Refer to SCP Interface section of the *Recommended Operating Conditions* table.

**Figure 3. SCP Timing Parameters**

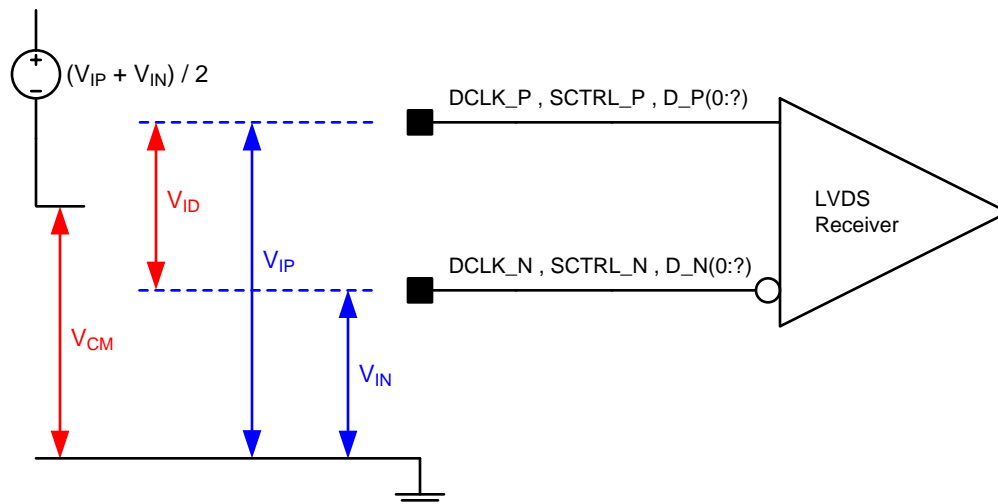

Refer to the LVDS Interface section of the *Recommended Operating Conditions* table.

Refer to *Pin Configuration and Functions* for a list of LVDS pins.

**Figure 4. LVDS Voltage Definitions (References)**

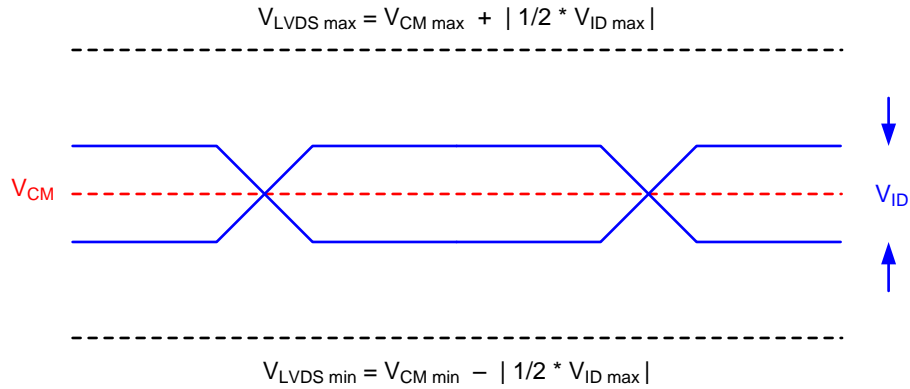

Not to scale.

Refer to the LVDS Interface section of the *Recommended Operating Conditions* table.

**Figure 5. LVDS Voltage Parameters**

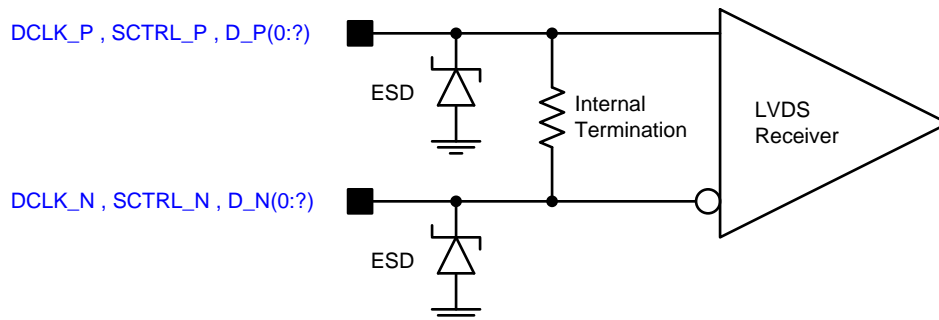

Refer to LVDS Interface section of the *Recommended Operating Conditions* table

Refer to *Pin Configuration and Functions* for list of LVDS pins.

**Figure 6. LVDS Equivalent Input Circuit**

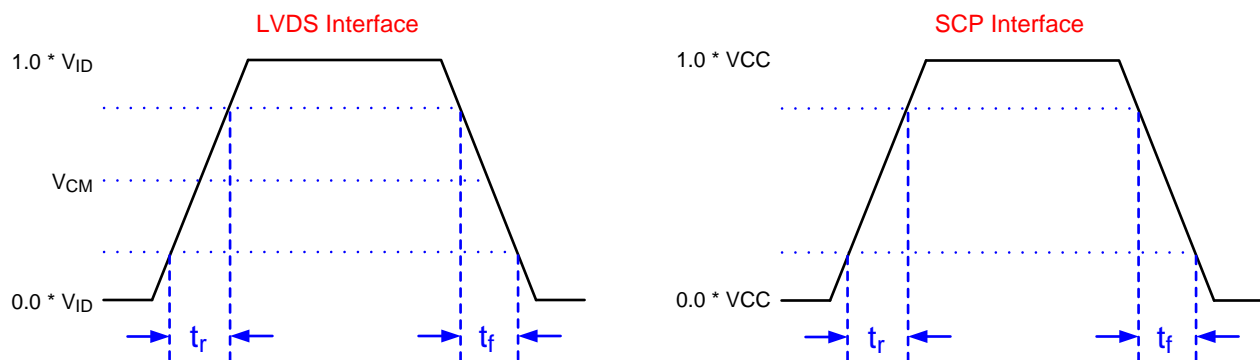

Not to scale.

Refer to the *Timing Requirements* table.

Refer to *Pin Configuration and Functions* for list of LVDS pins and SCP pins.

**Figure 7. Rise Time and Fall Time**



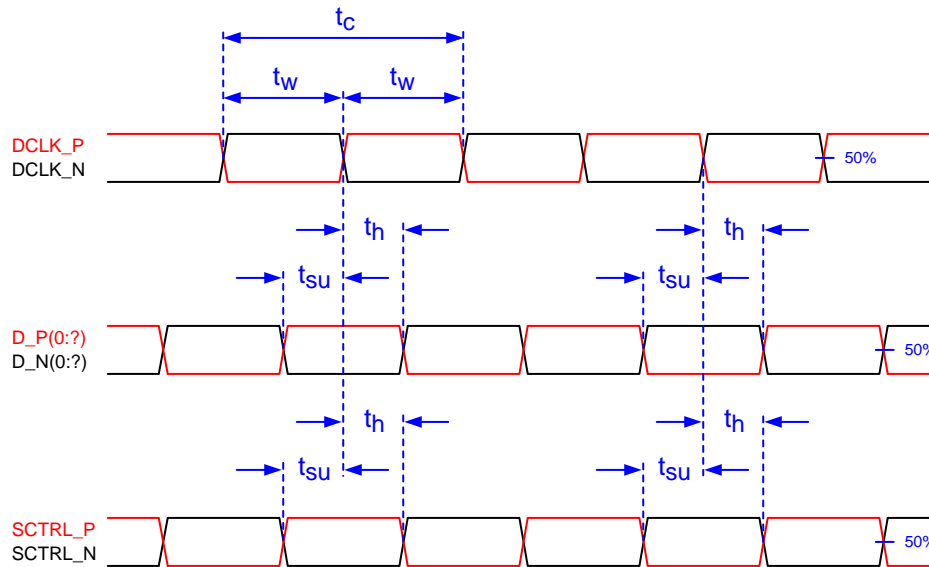

Not to scale.

Refer to LVDS INTERFACE section in the *Timing Requirements* table.

**Figure 8. Timing Requirement Parameter Definitions**

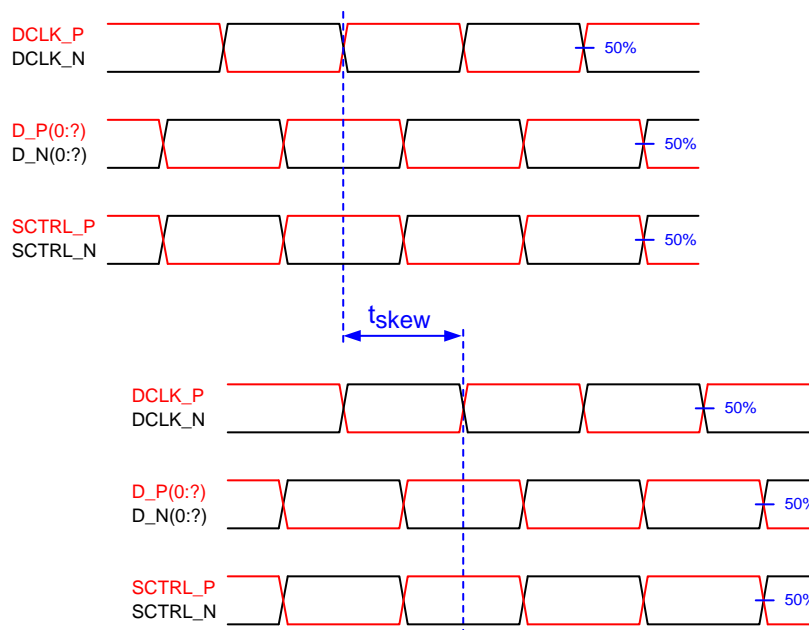

Not to scale.

Refer to LVDS INTERFACE in the *Timing Requirements* table.

**Figure 9. LVDS Interface Channel Skew Definition**

## 6.7 Typical Characteristics

The DLP6500 DMD is controlled by the DLPC900 controller. The controller has two modes of operation. The first is Video mode where the video source is displayed on the DMD. The second is Pattern mode, where the patterns are pre-stored in flash memory and then streamed to the DMD. The allowed DMD pattern rate depends on which mode and bit-depth is selected.

**Table 1. Bit Depth versus Pattern Rate**

BIT DEPTH	VIDEO MODE RATE (Hz)	PATTERN MODE RATE (Hz)
1	2880	9523
2	1440	3289
3	960	2638
4	720	1364
5	480	823
6	480	672
7	360	500
8	247	247

### 6.8 System Mounting Interface Loads

PARAMETER		MIN	NOM	MAX	UNIT
Maximum system mounting interface load to be applied to the:	Thermal Interface area			25	lbs
	Electrical Interface area			95	lbs
	Datum "A" Interface area <sup>(1)</sup>			90	lbs

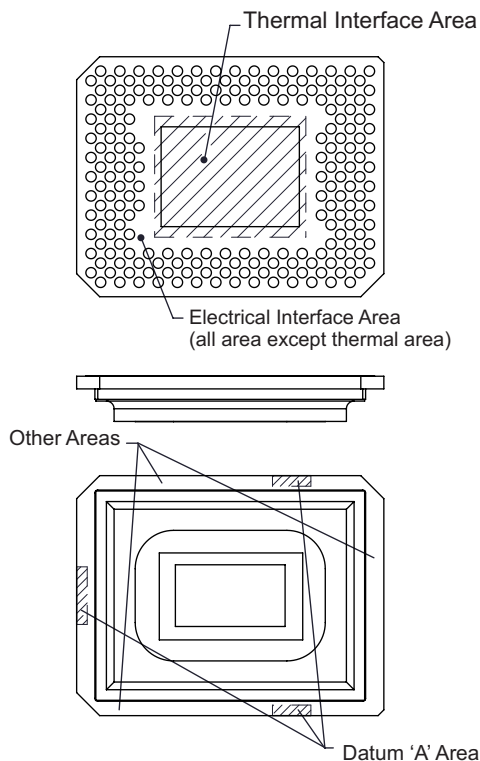

**Figure 10. System Mounting Interface Loads**

- (1) Combined loads of the thermal and electrical interface areas in excess of Datum "A" load shall be evenly distributed outside the Datum "A" area (95 + 25 – Datum "A").

### 6.9 Micromirror Array Physical Characteristics

			VALUE	UNIT
M	Number of active columns		1920	micromirrors
N	Number of active rows		1080	micromirrors
P	Micromirror (pixel) pitch		7.56	μm
	Micromirror active array width	M × P	14.5152	mm
	Micromirror active array height	N × P	8.1648	mm
	Micromirror active border	Pond of micromirror (POM) <sup>(1)</sup>	14	micromirrors /side

(1) The structure and qualities of the border around the active array includes a band of partially functional micromirrors called the POM. These micromirrors are structurally and/or electrically prevented from tilting toward the bright or ON state, but still require an electrical bias to tilt toward OFF.

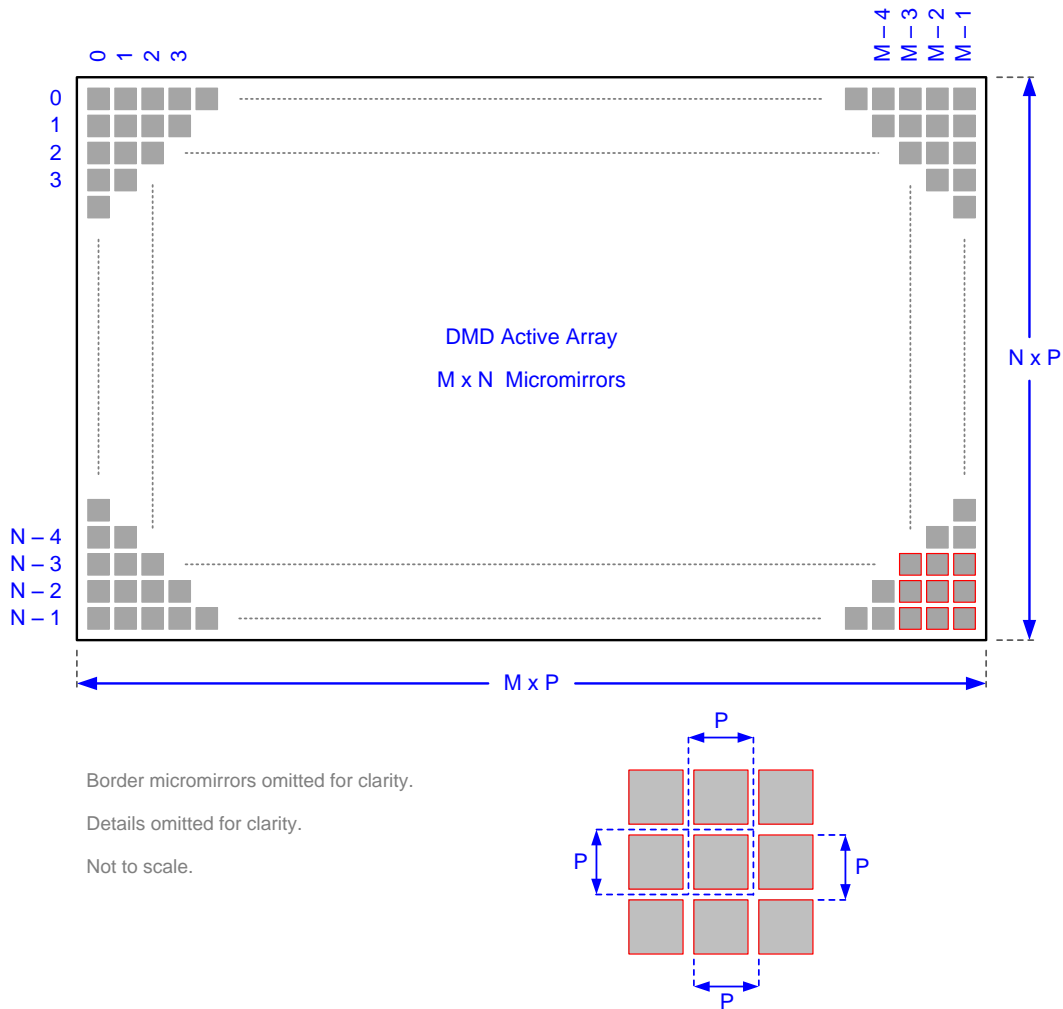

Refer to section [Micromirror Array Physical Characteristics](#) table for M, N, and P specifications.

**Figure 11. Micromirror Array Physical Characteristics**

## 6.10 Micromirror Array Optical Characteristics

See [Optical Interface and System Image Quality](#) for important information.

PARAMETER		CONDITIONS	MIN	NOM	MAX	UNIT
$\alpha$	Micromirror tilt angle	DMD landed state <sup>(1)</sup>		12		°
$\beta$	Micromirror tilt angle tolerance <sup>(1) (2)(3)(4)(5)</sup>		-1		1	°
	Micromirror tilt direction <sup>(5)(6) (7)</sup>	<a href="#">Figure 12</a>	44	45	46	°
	Number of out-of-specification micromirrors <sup>(7)</sup>	Adjacent micromirrors			0	micromirrors
		Non-adjacent micromirrors			10	
	Micromirror crossover time <sup>(8)(9)</sup>	Typical performance		2.5		μs
	Micromirror switching time <sup>(9)</sup>	Typical performance		5		μs
	DMD efficiency within the wavelength range 400 nm to 420 nm <sup>(10)</sup>			68%		
	DMD photopic efficiency within the wavelength range 420 nm to 700 nm <sup>(10)</sup>			66%		

- (1) Measured relative to the plane formed by the overall micromirror array.
- (2) Additional variation exists between the micromirror array and the package datums.
- (3) Represents the landed tilt angle variation relative to the nominal landed tilt angle.
- (4) Represents the variation that can occur between any two individual micromirrors, located on the same device or located on different devices.
- (5) For some applications, it is critical to account for the micromirror tilt angle variation in the overall system optical design. With some system optical designs, the micromirror tilt angle variation within a device may result in perceivable non-uniformities in the light field reflected from the micromirror array. With some system optical designs, the micromirror tilt angle variation between devices may result in colorimetry variations, system efficiency variations or system contrast variations.
- (6) When the micromirror array is landed (not parked), the tilt direction of each individual micromirror is dictated by the binary contents of the CMOS memory cell associated with each individual micromirror. A binary value of 1 results in a micromirror landing in the ON State direction. A binary value of 0 results in a micromirror landing in the OFF State direction.
- (7) An out-of-specification micromirror is defined as a micromirror that is unable to transition between the two landed states within the specified Micromirror Switching Time
- (8) Micromirror crossover time is primarily a function of the natural response time of the micromirrors.
- (9) Performance as measured at the start of life.
- (10) Efficiency numbers assume 24-degree illumination angle, F/2.4 illumination and collection cones, uniform source spectrum, and uniform pupil illumination. Efficiency numbers assume 100% electronic mirror duty cycle and do not include optical overfill loss. Note that this number is specified under conditions described above and deviations from the specified conditions could result in decreased efficiency.

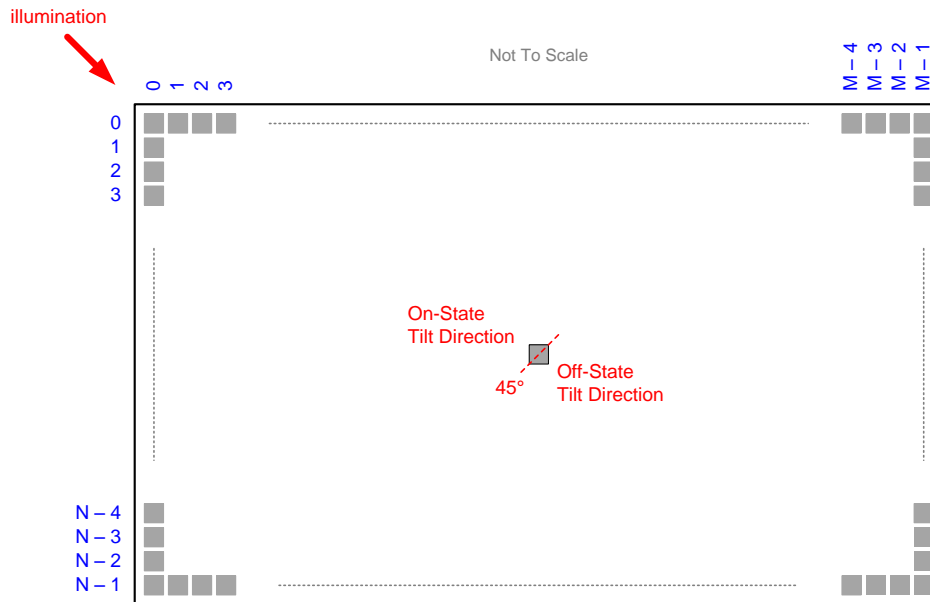

Refer to section [Micromirror Array Physical Characteristics](#) table for M, N, and P specifications.

**Figure 12. Micromirror Landed Orientation and Tilt**

### 6.11 Window Characteristics

PARAMETER <sup>(1)</sup>	CONDITIONS	MIN	TYP	MAX	UNIT
Window material designation	Corning 7056				
Window refractive index	at wavelength 589 nm		1.487		
Window aperture <sup>(2)</sup>	See <sup>(2)</sup>				
Illumination overfill <sup>(3)</sup>	See <sup>(3)</sup>				
Window transmittance, single-pass through both surfaces and glass <sup>(4)</sup>	At wavelength 405 nm. Applies to 0° and 24° AOI only.	95%			
	Minimum within the wavelength range 420 nm to 680 nm. Applies to all angles 0° to 30° AOI.	97%			
	Average over the wavelength range 420 nm to 680 nm. Applies to all angles 30° to 45° AOI.	97%			

- (1) See [Window Characteristics and Optics](#) for more information.
- (2) For details regarding the size and location of the window aperture, see the package mechanical characteristics listed in the Mechanical ICD in section Mechanical, Packaging, and Orderable Information.
- (3) Refer to [Illumination Overfill](#).
- (4) See the TI application report [DLPA031, Wavelength Transmittance Considerations for DLP™ DMD Window](#).

### 6.12 Chipset Component Usage Specification

The DLP6500FLQ is a component of one or more DLP® chipsets. Reliable function and operation of the DLP6500FLQ requires that it be used in conjunction with the other components of the applicable DLP chipset, including those components that contain or implement TI DMD control technology. TI DMD control technology is the TI technology and devices for operating or controlling a DLP DMD.

## 7 Detailed Description

### 7.1 Overview

DLP6500FLQ is a 0.65 inch diagonal spatial light modulator which consists of an array of highly reflective aluminum micromirrors. Pixel array size and square grid pixel arrangement are shown in [Figure 11](#).

The DMD is an electrical input, optical output micro-electrical-mechanical system (MEMS). The electrical interface is Low Voltage Differential Signaling (LVDS), Double Data Rate (DDR).

DLP6500FLQ DMD consists of a two-dimensional array of 1-bit CMOS memory cells. The array is organized in a grid of M memory cell columns by N memory cell rows. Refer to the [Functional Block Diagram](#).

The positive or negative deflection angle of the micromirrors can be individually controlled by changing the address voltage of underlying CMOS addressing circuitry and micromirror reset signals (MBRST).

Each cell of the  $M \times N$  memory array drives its true and complement ('Q' and 'QB') data to two electrodes underlying one micromirror, one electrode on each side of the diagonal axis of rotation. Refer to [Micromirror Array Optical Characteristics](#). The micromirrors are electrically tied to the micromirror reset signals (MBRST) and the micromirror array is divided into reset groups.

Electrostatic potentials between a micromirror and its memory data electrodes cause the micromirror to tilt toward the illumination source in a DLP projection system or away from it, thus reflecting its incident light into or out of an optical collection aperture. The positive (+) tilt angle state corresponds to an 'on' pixel, and the negative (-) tilt angle state corresponds to an 'off' pixel.

Refer to [Micromirror Array Optical Characteristics](#) for the  $\pm$  tilt angle specifications. Refer to [Pin Configuration and Functions](#) for more information on micromirror reset control.

## 7.2 Functional Block Diagram

Not to Scale. Details Omitted for Clarity. See Accompanying Notes in this Section.

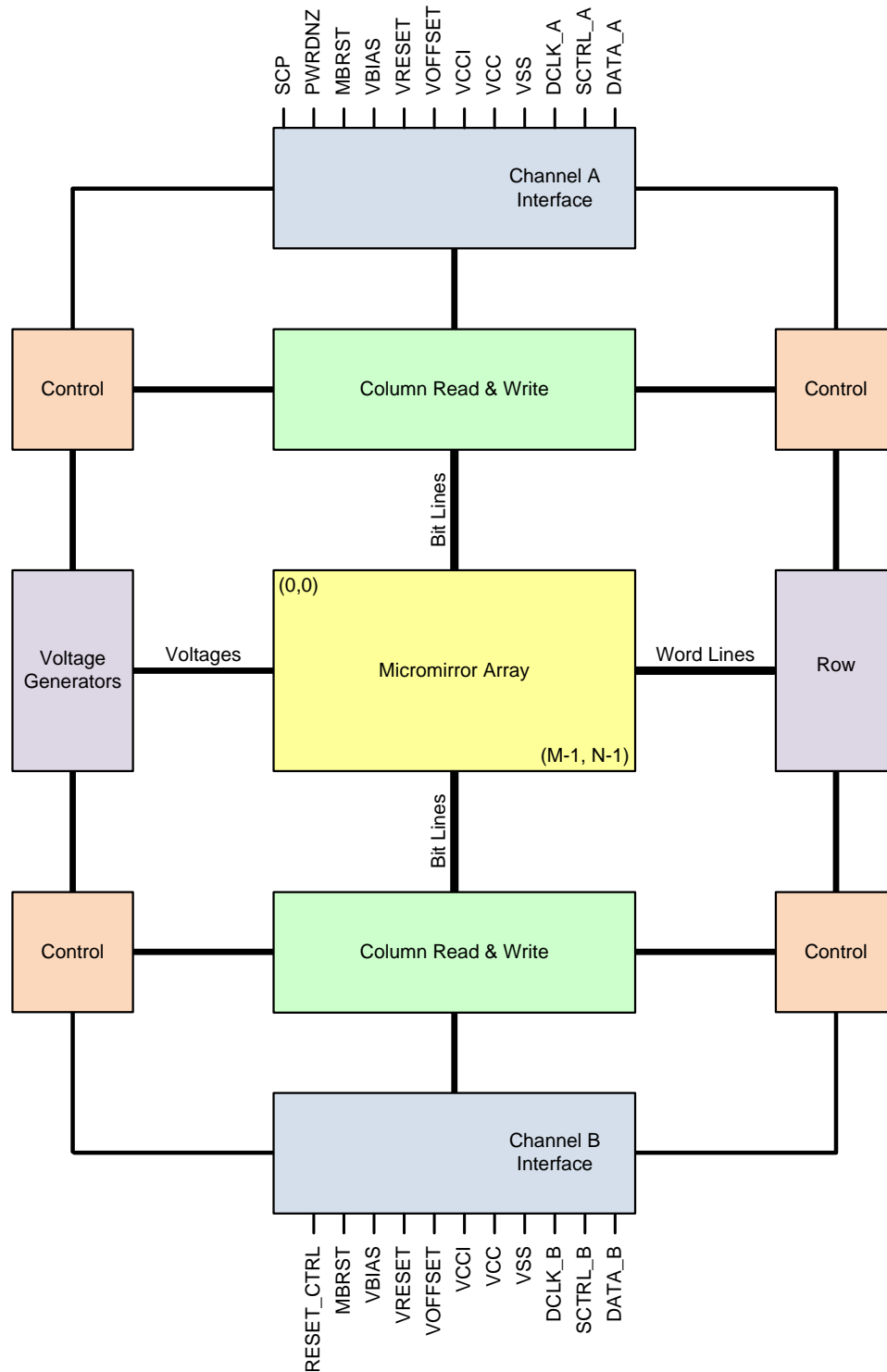

For pin details on Channels A, and B, refer to [Pin Configuration and Functions](#) and [Timing Requirements](#) notes 5 thru 8.

Refer to [Micromirror Array Physical Characteristics](#) for dimensions, orientation, and tilt angle.



### 7.3 Feature Description

DLP6500FLQ device consists of highly reflective, digitally switchable, micrometer-sized mirrors (micromirrors) organized in a two-dimensional orthogonal pixel array. Refer to [Figure 11](#) and [Figure 13](#).

Each aluminum micromirror is switchable between two discrete angular positions,  $-\alpha$  and  $+\alpha$ . The angular positions are measured relative to the micromirror array plane, which is parallel to the silicon substrate. Refer to [Micromirror Array Optical Characteristics](#) and [Figure 14](#).

The parked position of the micromirror is not a latched position and is therefore not necessarily perfectly parallel to the array plane. Individual micromirror flat state angular positions may vary. Tilt direction of the micromirror is perpendicular to the hinge-axis. The on-state landed position is directed toward the left-top edge of the package, as shown in [Figure 13](#).

Each individual micromirror is positioned over a corresponding CMOS memory cell. The angular position of a specific micromirror is determined by the binary state (logic 0 or 1) of the corresponding CMOS memory cell contents, after the mirror clocking pulse is applied. The angular position ( $-\alpha$  and  $+\alpha$ ) of the individual micromirrors changes synchronously with a micromirror clocking pulse, rather than being coincident with the CMOS memory cell data update.

Writing logic 1 into a memory cell followed by a mirror clocking pulse results in the corresponding micromirror switching to a  $+\alpha$  position. Writing logic 0 into a memory cell followed by a mirror clocking pulse results in the corresponding micromirror switching to a  $-\alpha$  position.

Updating the angular position of the micromirror array consists of two steps. First, update the contents of the CMOS memory. Second, apply a micromirror reset to all or a portion of the micromirror array (depending upon the configuration of the system). Micromirror reset pulses are generated internally by the DLP6500FLQ DMD with application of the pulses being coordinated by the DLPC900 display controller.

For more information, see the TI application report [DLPA008A](#), *DMD101: Introduction to Digital Micromirror Device (DMD) Technology*.

Feature Description (continued)

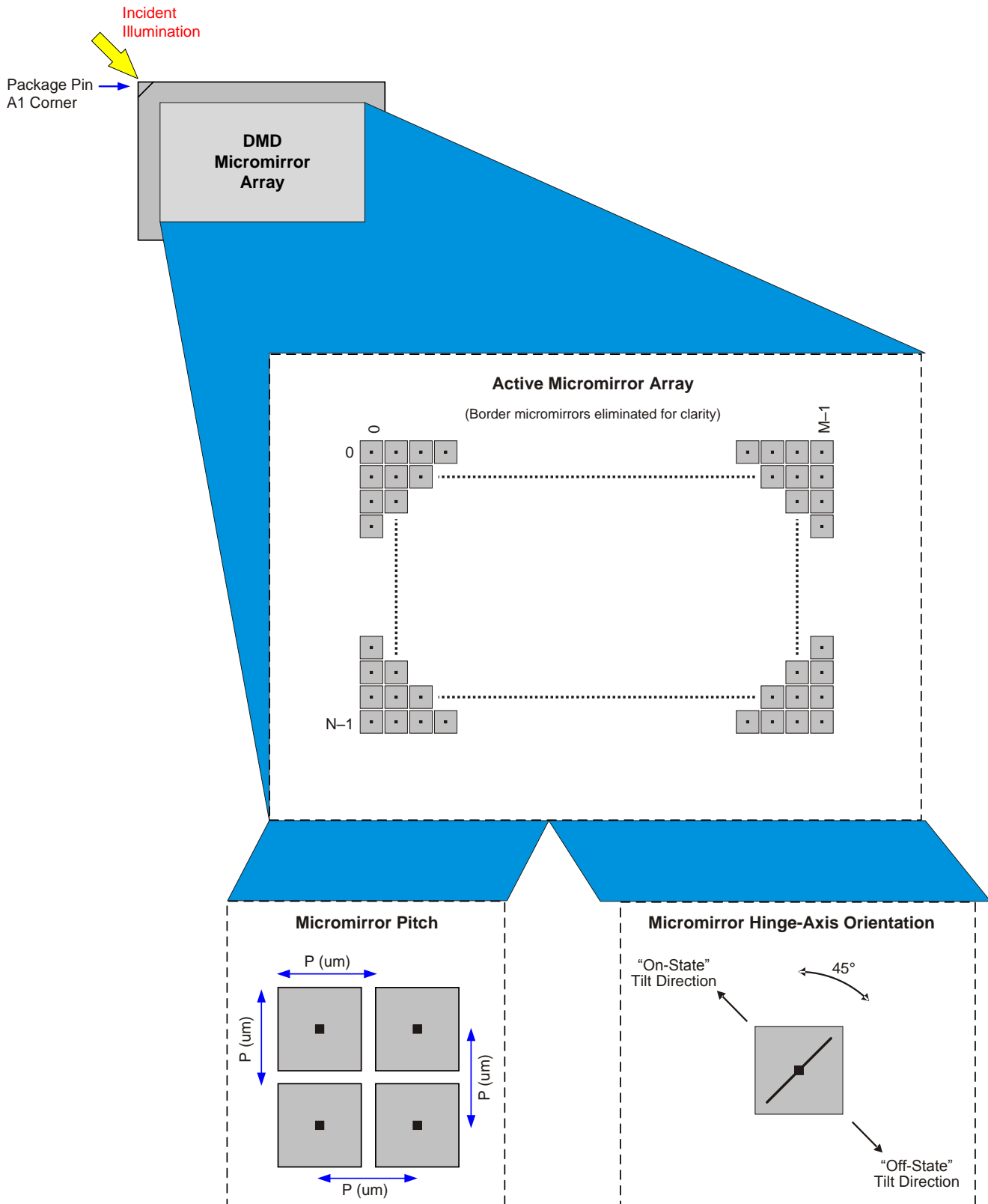

Refer to *Micromirror Array Physical Characteristics*, Figure 11, and Figure 12.

Figure 13. Micromirror Array, Pitch, Hinge Axis Orientation

Feature Description (continued)

Details Omitted For Clarity.  
Not To Scale.

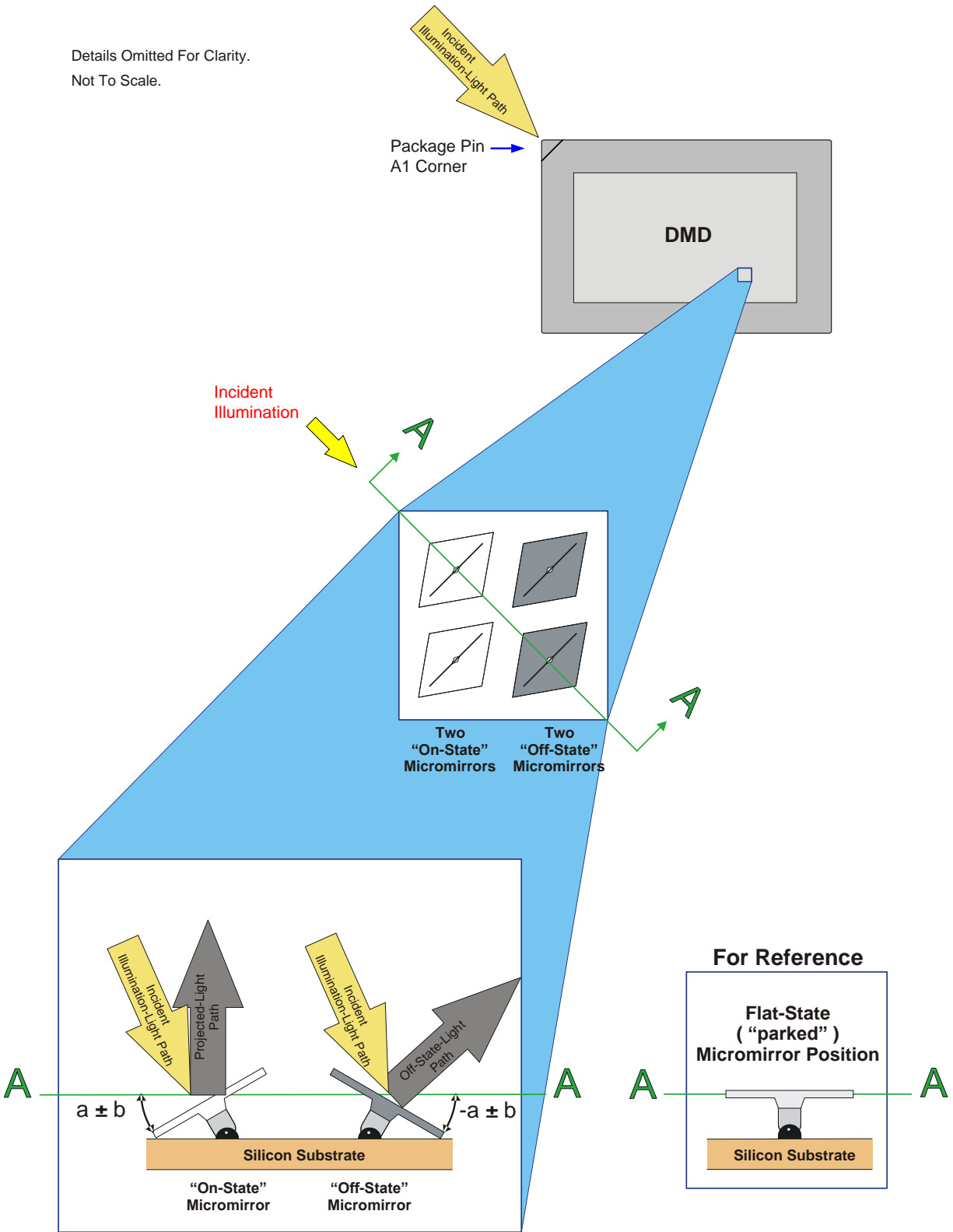

Refer to *Micromirror Array Optical Characteristics*, and Figure 12.

Figure 14. Micromirror States: On, Off, Flat

## 7.4 Device Functional Modes

DLP6500FLQ is part of the chipset comprising of the DLP6500FLQ DMD and DLPC900 display controller. To ensure reliable operation, DLP6500FLQ DMD must always be used with a DLPC900 display controller.

DMD functional modes are controlled by the DLPC900 digital display controller. See the DLPC900 data sheet listed in Related Documentation. Contact a TI applications engineer for more information.

## 7.5 Window Characteristics and Optics

---

### NOTE

TI assumes no responsibility for image quality artifacts or DMD failures caused by optical system operating conditions exceeding limits described previously.

---

### 7.5.1 Optical Interface and System Image Quality

TI assumes no responsibility for end-equipment optical performance. Achieving the desired end-equipment optical performance involves making trade-offs between numerous component and system design parameters. Optimizing system optical performance and image quality strongly relate to optical system design parameter trades. Although it is not possible to anticipate every conceivable application, projector image quality and optical performance is contingent on compliance to the optical system operating conditions described in the following sections.

### 7.5.2 Numerical Aperture and Stray Light Control

The angle defined by the numerical aperture of the illumination and projection optics at the DMD optical area should be the same. This angle should not exceed the nominal device mirror tilt angle unless appropriate apertures are added in the illumination and/or projection pupils to block out flat-state and stray light from the projection lens. The mirror tilt angle defines DMD capability to separate the "ON" optical path from any other light path, including undesirable flat-state specular reflections from the DMD window, DMD border structures, or other system surfaces near the DMD such as prism or lens surfaces. If the numerical aperture exceeds the mirror tilt angle, or if the projection numerical aperture angle is more than two degrees larger than the illumination numerical aperture angle, objectionable artifacts in the display's border and/or active area could occur.

### 7.5.3 Pupil Match

TI's optical and image quality specifications assume that the exit pupil of the illumination optics is nominally centered within 2° (two degrees) of the entrance pupil of the projection optics. Misalignment of pupils can create objectionable artifacts in the display's border and/or active area, which may require additional system apertures to control, especially if the numerical aperture of the system exceeds the pixel tilt angle.

### 7.5.4 Illumination Overfill

The active area of the device is surrounded by an aperture on the inside DMD window surface that masks structures of the DMD device assembly from normal view. The aperture is sized to anticipate several optical operating conditions. Overfill light illuminating the window aperture can create artifacts from the edge of the window aperture opening and other surface anomalies that may be visible on the screen. The illumination optical system should be designed to limit light flux incident anywhere on the window aperture from exceeding approximately 10% of the average flux level in the active area. Depending on the particular system's optical architecture, overfill light may have to be further reduced below the suggested 10% level in order to be acceptable.

## 7.6 Micromirror Array Temperature Calculation

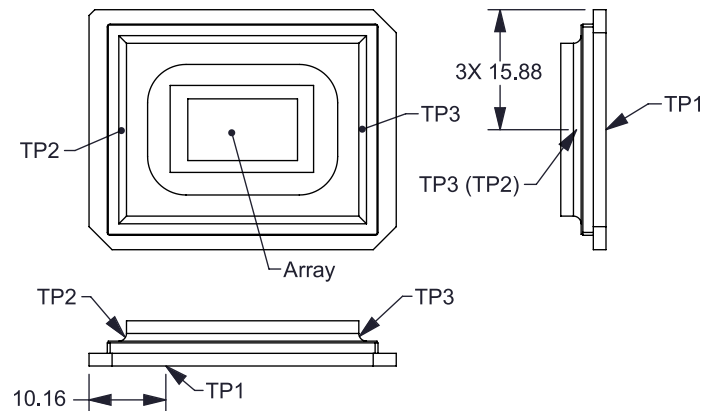

Figure 15. DMD Thermal Test Points

Micromirror array temperature can be computed analytically from measurement points on the outside of the package, the ceramic package thermal resistance, the electrical power dissipation, and the illumination heat load. The relationship between micromirror array temperature and the reference ceramic temperature is provided by the following equations:

$$T_{\text{ARRAY}} = T_{\text{CERAMIC}} + (Q_{\text{ARRAY}} \times R_{\text{ARRAY-TO-CERAMIC}}) \quad (1)$$

$$Q_{\text{ARRAY}} = Q_{\text{ELECTRICAL}} + Q_{\text{ILLUMINATION}} \quad (2)$$

$$Q_{\text{ILLUMINATION}} = (C_{\text{L2W}} \times \text{SL}) \quad (3)$$

Where:

$T_{\text{ARRAY}}$  = Computed micromirror array temperature (°C)

$T_{\text{CERAMIC}}$  = Measured ceramic temperature (°C), TP1 location in [Figure 15](#)

$R_{\text{ARRAY-TO-CERAMIC}}$  = DMD package thermal resistance from micromirror array to outside ceramic (°C/W) specified in [Thermal Information](#)

$Q_{\text{ARRAY}}$  = Total DMD power; electrical, specified in [Electrical Characteristics](#), plus absorbed (calculated) (W)

$Q_{\text{ELECTRICAL}}$  = Nominal DMD electrical power dissipation (W), specified in [Electrical Characteristics](#)

$C_{\text{L2W}}$  = Conversion constant for screen lumens to absorbed optical power on the DMD (W/lm) specified below

SL = Measured ANSI screen lumens (lm)

Electrical power dissipation of the DMD is variable and depends on the voltages, data rates and operating frequencies. The nominal electrical power dissipation to use when calculating array temperature is 2.9 Watts. Absorbed optical power from the illumination source is variable and depends on the operating state of the micromirrors and the intensity of the light source. Equations shown above are valid for a 1-chip DMD system with total projection efficiency through the projection lens from DMD to the screen of 87%.

The conversion constant  $C_{\text{L2W}}$  is based on the DMD micromirror array characteristics. It assumes a spectral efficiency of 300 lm/W for the projected light and illumination distribution of 83.7% on the DMD active array, and 16.3% on the DMD array border and window aperture. The conversion constant is calculated to be 0.00293 W/lm.

Sample Calculation for typical projection application:

$T_{\text{CERAMIC}} = 55^{\circ}\text{C}$ , assumed system measurement; see [Recommended Operating Conditions](#) for specific limits

SL = 2000 lm

$Q_{\text{ELECTRICAL}} = 2.9 \text{ W}$  (see the maximum power specifications in [Electrical Characteristics](#))

$C_{\text{L2W}} = 0.00293 \text{ W/lm}$

$Q_{\text{ARRAY}} = 2.9 \text{ W} + (0.00293 \text{ W/lm} \times 2000 \text{ lm}) = 8.76 \text{ W}$

$T_{\text{ARRAY}} = 55^{\circ}\text{C} + (8.76 \text{ W} \times 0.7 \times \text{C/W}) = 61.13^{\circ}\text{C}$

## 7.7 Micromirror Landed-on/Landed-Off Duty Cycle

### 7.7.1 Definition of Micromirror Landed-On/Landed-Off Duty Cycle

The micromirror landed-on/landed-off duty cycle (landed duty cycle) denotes the amount of time (as a percentage) that an individual micromirror is landed in the On-state versus the amount of time the same micromirror is landed in the Off-state.

As an example, a landed duty cycle of 100/0 indicates that the referenced pixel is in the On-state 100% of the time (and in the Off-state 0% of the time); whereas 0/100 would indicate that the pixel is in the Off-state 100% of the time. Likewise, 50/50 indicates that the pixel is On 50% of the time and Off 50% of the time.

Note that when assessing landed duty cycle, the time spent switching from one state (ON or OFF) to the other state (OFF or ON) is considered negligible and is thus ignored.

Since a micromirror can only be landed in one state or the other (On or Off), the two numbers (percentages) always add to 100.

### 7.7.2 Landed Duty Cycle and Useful Life of the DMD

Knowing the long-term average landed duty cycle (of the end product or application) is important because subjecting all (or a portion) of the DMD's micromirror array (also called the active array) to an asymmetric landed duty cycle for a prolonged period of time can reduce the DMD's usable life.

Note that it is the symmetry/asymmetry of the landed duty cycle that is of relevance. The symmetry of the landed duty cycle is determined by how close the two numbers (percentages) are to being equal. For example, a landed duty cycle of 50/50 is perfectly symmetrical whereas a landed duty cycle of 100/0 or 0/100 is perfectly asymmetrical.

### 7.7.3 Landed Duty Cycle and Operational DMD Temperature

Operational DMD Temperature and Landed Duty Cycle interact to affect the DMD's usable life, and this interaction can be exploited to reduce the impact that an asymmetrical Landed Duty Cycle has on the DMD's usable life. This is quantified in the de-rating curve shown in [Figure 1](#). The importance of this curve is that:

- All points along this curve represent the same usable life.
- All points above this curve represent lower usable life (and the further away from the curve, the lower the usable life).
- All points below this curve represent higher usable life (and the further away from the curve, the higher the usable life).

In practice, this curve specifies the Maximum Operating DMD Temperature that the DMD should be operated at for a given long-term average Landed Duty Cycle.

### 7.7.4 Estimating the Long-Term Average Landed Duty Cycle of a Product or Application

During a given period of time, the Landed Duty Cycle of a given pixel follows from the image content being displayed by that pixel.

For example, in the simplest case, when displaying pure-white on a given pixel for a given time period, that pixel will experience a 100/0 Landed Duty Cycle during that time period. Likewise, when displaying pure-black, the pixel will experience a 0/100 Landed Duty Cycle.

Between the two extremes (ignoring for the moment color and any image processing that may be applied to an incoming image), the Landed Duty Cycle tracks one-to-one with the gray scale value, as shown in [Table 2](#).

**Table 2. Grayscale Value and Landed Duty Cycle**

GRAYSCALE VALUE	LANDED DUTY CYCLE
0%	0/100
10%	10/90
20%	20/80
30%	30/70
40%	40/60
50%	50/50
60%	60/40
70%	70/30
80%	80/20
90%	90/10
100%	100/0

Accounting for color rendition (but still ignoring image processing) requires knowing both the color intensity (from 0% to 100%) for each constituent primary color (red, green, and/or blue) for the given pixel as well as the color cycle time for each primary color, where “color cycle time” is the total percentage of the frame time that a given primary must be displayed in order to achieve the desired white point.

During a given period of time, the landed duty cycle of a given pixel can be calculated as follows:

$$\text{Landed Duty Cycle} = (\text{Red\_Cycle\_}\% \times \text{Red\_Scale\_Value}) + (\text{Green\_Cycle\_}\% \times \text{Green\_Scale\_Value}) + (\text{Blue\_Cycle\_}\% \times \text{Blue\_Scale\_Value})$$

Where:

Red\_Cycle\_%, Green\_Cycle\_%, and Blue\_Cycle\_%, represent the percentage of the frame time that Red, Green, and Blue are displayed (respectively) to achieve the desired white point.

For example, assume that the red, green and blue color cycle times are 50%, 20%, and 30% respectively (in order to achieve the desired white point), then the Landed Duty Cycle for various combinations of red, green, blue color intensities would be as shown in [Table 3](#).

**Table 3. Example Landed Duty Cycle for Full-Color**

Red Cycle Percentage 50%	Green Cycle Percentage 20%	Blue Cycle Percentage 30%	Landed Duty Cycle
Red Scale Value	Green Scale Value	Blue Scale Value	
0%	0%	0%	0/100
100%	0%	0%	50/50
0%	100%	0%	20/80
0%	0%	100%	30/70
12%	0%	0%	6/94
0%	35%	0%	7/93
0%	0%	60%	18/82
100%	100%	0%	70/30
0%	100%	100%	50/50
100%	0%	100%	80/20
12%	35%	0%	13/87
0%	35%	60%	25/75
12%	0%	60%	24/76
100%	100%	100%	100/0

## 8 Application and Implementation

### NOTE

Information in the following applications sections is not part of the TI component specification, and TI does not warrant its accuracy or completeness. TI's customers are responsible for determining suitability of components for their purposes. Customers should validate and test their design implementation to confirm system functionality.

### 8.1 Application Information

The DLP6500FLQ along with the DLPC900 controller provides a solution for many applications including structured light and video projection. The DMD is a spatial light modulator, which reflects incoming light from an illumination source to one of two directions, with the primary direction being into a projection or collection optic. Each application is derived primarily from the optical architecture of the system and the format of the data coming into the DLPC900. Applications of interest include machine vision, 3D printing, and lithography.

### 8.2 Typical Application

A typical embedded system application using the DLPC900 controller and a DLP6500FLQ is shown in Figure 16. In this configuration, the DLPC900 controller supports a 24-bit parallel RGB input, typical of LCD interfaces, from an external source or processor. This system configuration supports still and motion video sources plus sequential pattern mode. Refer to Related Documents for the DLPC900 digital controller data sheet.

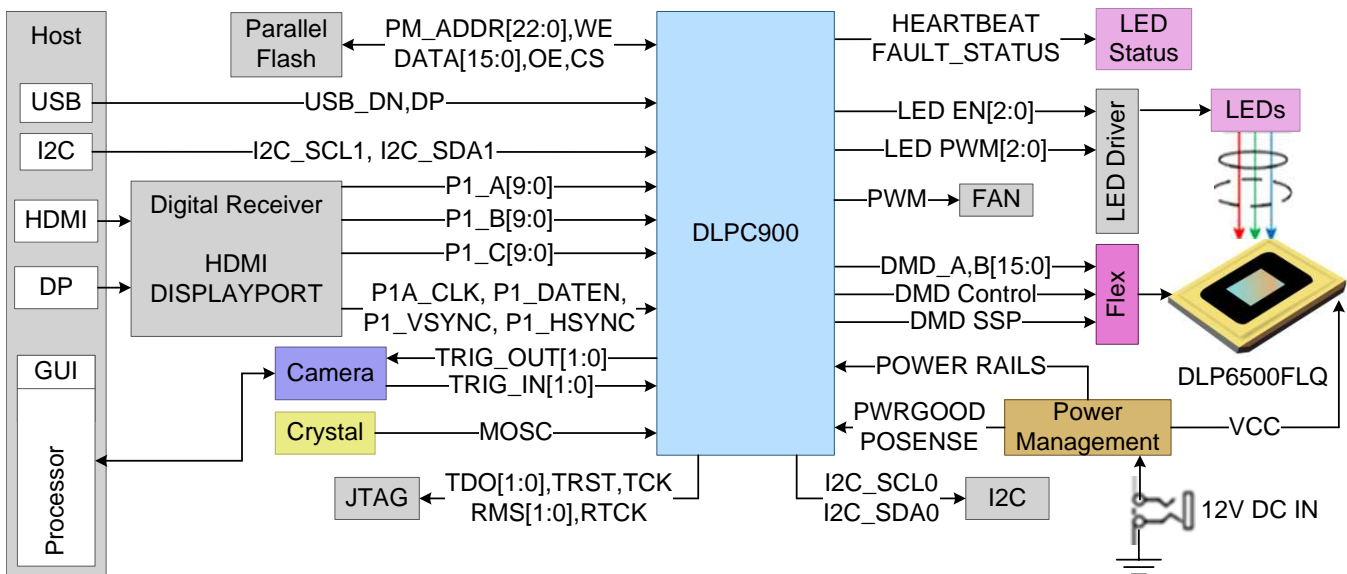

Figure 16. Typical Application Schematic

#### 8.2.1 Design Requirements

Detailed design requirements are located in the DLPC900 digital controller data sheet. Refer to Related Documents.

#### 8.2.2 Detailed Design Procedure

See the reference design schematic for connecting together the DLPC900 display controller and the DLP6500 DMD. An example board layout is included in the reference design data base. Layout guidelines should be followed for reliability.



## 9 Power Supply Recommendations

### 9.1 DMD Power Supply Requirements

The following power supplies are all required to operate the DMD: VCC, VCCI, VOFFSET, VBIAS, and VRESET. VSS must also be connected. DMD power-up and power-down sequencing is strictly controlled by the DLPC900 device.

#### CAUTION

For reliable operation of the DMD, the following power supply sequencing requirements must be followed. Failure to adhere to the prescribed power-up and power-down procedures may affect device reliability. VCC, VCCI, VOFFSET, VBIAS, and VRESET power supplies have to be coordinated during power-up and power-down operations. VSS must also be connected. Failure to meet any of the below requirements will result in a significant reduction in the DMD's reliability and lifetime. Refer to [Figure 17](#).

### 9.2 DMD Power Supply Power-Up Procedure

- During power-up, VCC and VCCI must always start and settle before VOFFSET, VBIAS, and VRESET voltages are applied to the DMD.
- During power-up, it is a strict requirement that the delta between VBIAS and VOFFSET must be within the specified limit shown in [Recommended Operating Conditions](#). During power-up, VBIAS does not have to start after VOFFSET.
- During power-up, there is no requirement for the relative timing of VRESET with respect to VOFFSET and VBIAS.
- Power supply slew rates during power-up are flexible, provided that the transient voltage levels follow the requirements listed in [Absolute Maximum Ratings](#), in [Recommended Operating Conditions](#), and in [Figure 17](#).
- During power-up, LVCMOS input pins shall not be driven high until after VCC and VCCI have settled at operating voltages listed in [Recommended Operating Conditions](#).

### 9.3 DMD Power Supply Power-Down Procedure

- During power-down, VCC and VCCI must be supplied until after VBIAS, VRESET, and VOFFSET are discharged to within the specified limit of ground. Refer to [Table 4](#).
- During power-down, it is a strict requirement that the delta between VBIAS and VOFFSET must be within the specified limit shown in [Recommended Operating Conditions](#). During power-down, it is not mandatory to stop driving VBIAS prior to VOFFSET.
- During power-down, there is no requirement for the relative timing of VRESET with respect to VOFFSET and VBIAS.
- Power supply slew rates during power-down are flexible, provided that the transient voltage levels follow the requirements listed in [Absolute Maximum Ratings](#), in [Recommended Operating Conditions](#), and in [Figure 17](#).
- During power-down, LVCMOS input pins must be less than specified in [Recommended Operating Conditions](#).

### DMD Power Supply Power-Down Procedure (continued)

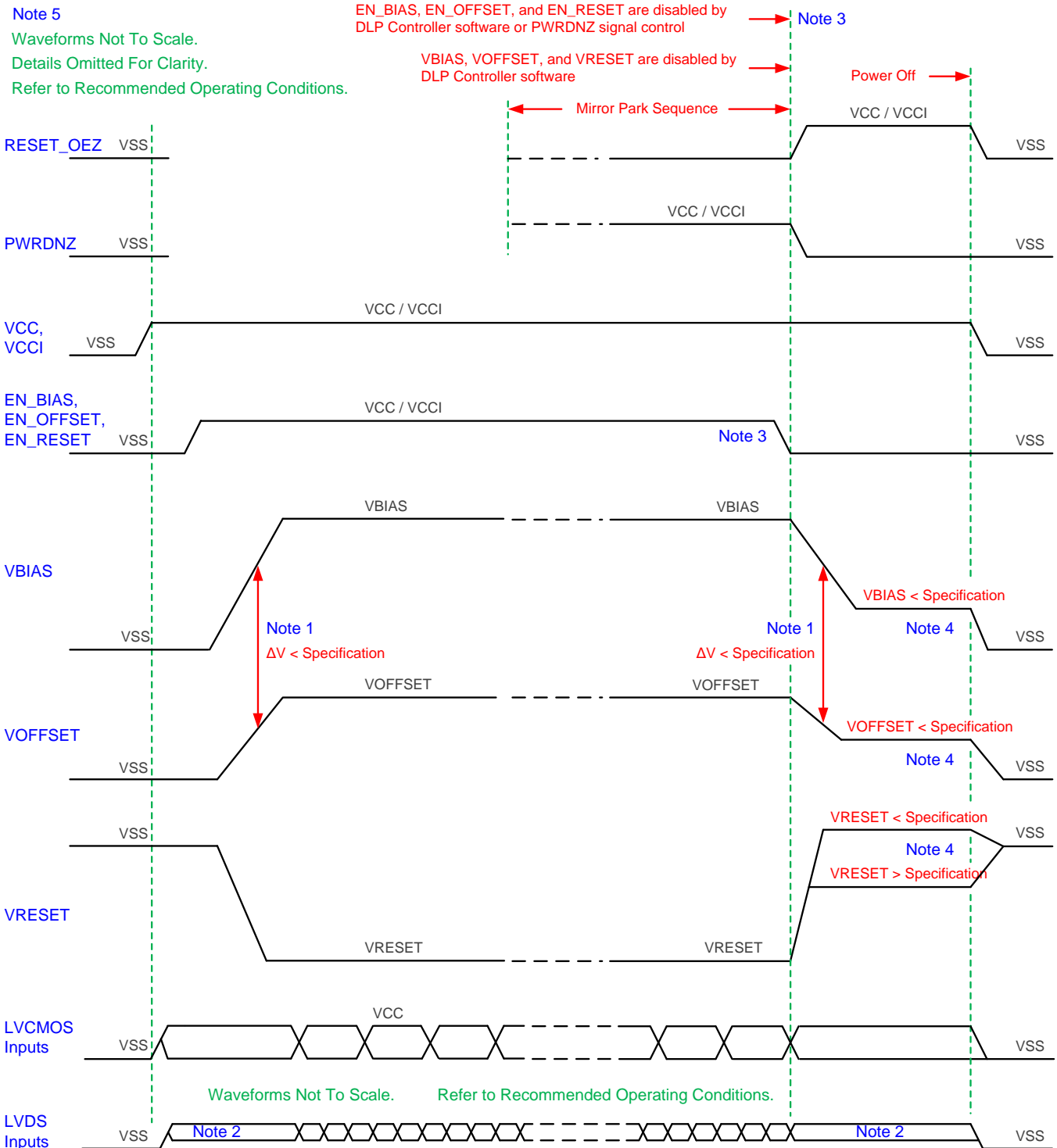

**Figure 17. DMD Power Supply Sequencing Requirements**

1. To prevent excess current, the supply voltage delta  $|VBIAS - VOFFSET|$  must be less than specified in *Recommended Operating Conditions*. OEMs may find that the most reliable way to ensure this is to power VOFFSET prior to VBIAS during power-up and to remove VBIAS prior to VOFFSET during power-down.
2. LVDS signals are less than the input differential voltage (VID) maximum specified in *Recommended*

## DMD Power Supply Power-Down Procedure (continued)

*Operating Conditions.* During power-down, LVDS signals are less than the high level input voltage (VIH) maximum specified in *Recommended Operating Conditions*.

3. When system power is interrupted, the DLP controller (DLPC900) initiates a hardware power-down that activates PWRDNZ and disables VBIAS, VRESET and VOFFSET after the micromirror park sequence. Software power-down disables VBIAS, VRESET, and VOFFSET after the micromirror park sequence through software control. For either case, enable signals EN\_BIAS, EN\_OFFSET, and EN\_RESET are used to disable VBIAS, VOFFSET, and VRESET, respectfully.
4. Refer to DMD Power Down Sequence Requirements.
5. Figure not to scale. Details have been omitted for clarity. Refer *Recommended Operating Conditions*.

**Table 4. DMD Power-Down Sequence Requirements**

PARAMETER		MIN	MAX	UNIT
VBIAS	Supply voltage level during power-down sequence		4.0	V
VOFFSET	Supply voltage level during power-down sequence		4.0	V
VRESET	Supply voltage level during power-down sequence	-4.0	0.5	V

## 10 Layout

### 10.1 Layout Guidelines

The DLP6500FLQ along with one DLPC900 controller provides a solution for many applications including structured light and video projection. This section provides layout guidelines for the DLP6500FLQ.

#### 10.1.1 General PCB Recommendations

The PCB shall be designed to IPC2221 and IPC2222, Class 2, Type Z, at level B producibility and built to IPC6011 and IPC6012, class 2. The PCB board thickness to be 0.062 inches +/- 10%, using standard FR-4 material, and applies after all lamination and plating processes, measured from copper to copper.

Two-ounce copper planes are recommended in the PCB design in order to achieve needed thermal connectivity. Refer to Related Documents for the DLPC900 Digital Controller Data Sheet for related information on the DMD Interface Considerations.

High-speed interface waveform quality and timing on the DLPC900 controller (that is, the LVDS DMD interface) is dependent on the following factors:

- Total length of the interconnect system
- Spacing between traces
- Characteristic impedance
- Etch losses
- How well matched the lengths are across the interface

Thus, ensuring positive timing margin requires attention to many factors. As an example, DMD interface system timing margin can be calculated as follows:

- Setup Margin = (controller output setup) – (DMD input setup) – (PCB routing mismatch) – (PCB SI degradation)
- Hold-time Margin = (controller output hold) – (DMD input hold) – (PCB routing mismatch) – (PCB SI degradation)

The PCB SI degradation is the signal integrity degradation due to PCB affects which includes such things as simultaneously switching output (SSO) noise, crosstalk, and inter-symbol-interference (ISI) noise.

DLPC900 I/O timing parameters can be found in DLPC900 Digital Controller Data Sheet. Similarly, PCB routing mismatch can be easily budgeted and met via controlled PCB routing. However, PCB SI degradation is not as easy to determine.

In an attempt to minimize the signal integrity analysis that would otherwise be required, the following PCB design guidelines provide a reference of an interconnect system that satisfies both waveform quality and timing requirements (accounting for both PCB routing mismatch and PCB SI degradation). Deviation from these recommendations should be confirmed with PCB signal integrity analysis or lab measurements.

### 10.2 Layout Example

#### 10.2.1 Board Stack and Impedance Requirements

Refer to [Figure 18](#) for guidance on the parameters.

PCB design:

Configuration:	Asymmetric dual stripline
Etch thickness (T):	1.0-oz copper (1.2 mil)
Flex etch thickness (T):	0.5-oz copper (0.6 mil)
Single-ended signal impedance:	50 Ω (±10%)
Differential signal impedance:	100 Ω (±10%)

**Layout Example (continued)**

PCB stack-up:

- Reference plane 1 is assumed to be a ground plane for proper return path. Asymmetric dual stripline
- Reference plane 2 is assumed to be the I/O power plane or ground. 1.0-oz copper (1.2 mil)
- Dielectric FR4, (Er): 4.2 (nominal)
- Signal trace distance to reference plane 1 (H1): 5.0 mil (nominal)
- Signal trace distance to reference plane 2 (H2): 34.2 mil (nominal)

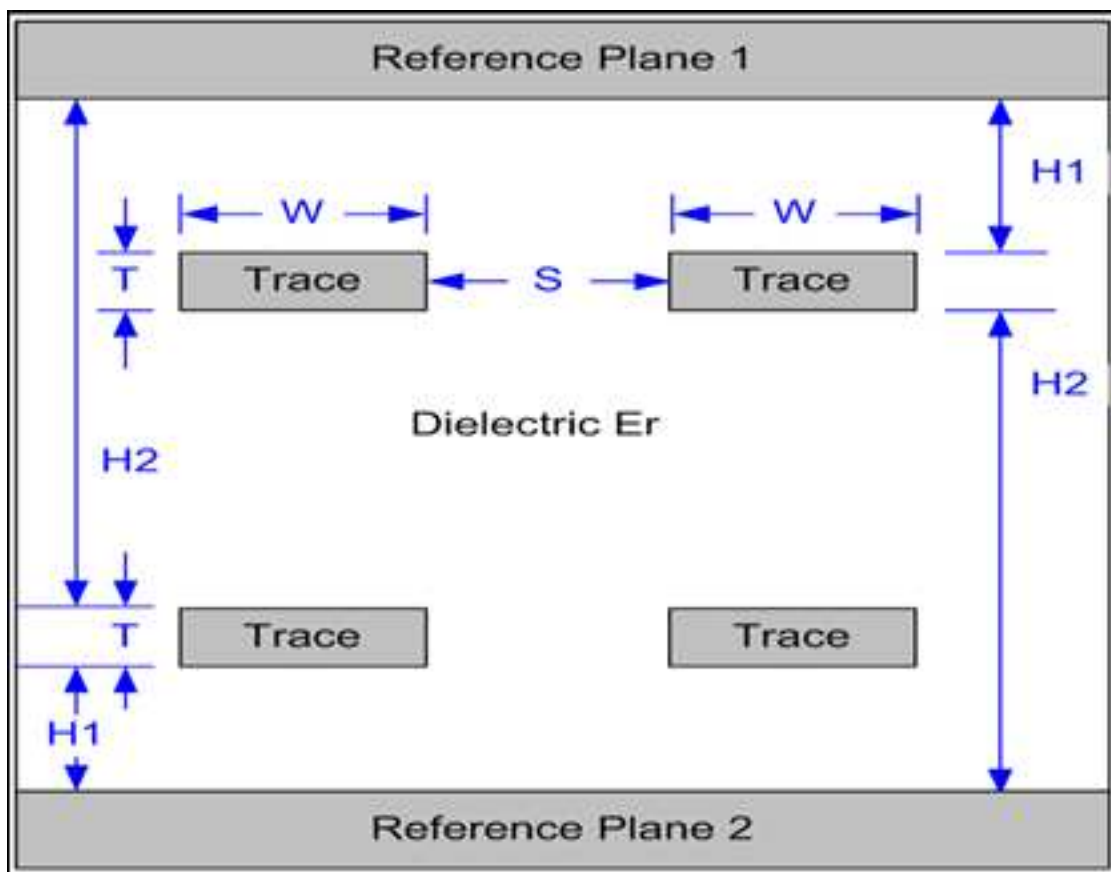

Figure 18. PCB Stack Geometries

Table 5. General PCB Routing (Applies to All Corresponding PCB Signals)

PARAMETER	APPLICATION	SINGLE-ENDED SIGNALS	DIFFERENTIAL PAIRS	UNIT
Line width (W)	Escape routing in ball field	4 (0.1)	4 (0.1)	mil (mm)
	PCB etch data or control	7 (0.18)	4.25 (0.11)	mil (mm)
	PCB etch clocks	7 (0.18)	4.25 (0.11)	mil (mm)

**Layout Example (continued)**
**Table 5. General PCB Routing (Applies to All Corresponding PCB Signals) (continued)**

PARAMETER	APPLICATION	SINGLE-ENDED SIGNALS	DIFFERENTIAL PAIRS	UNIT
Differential signal pair spacing (S)	PCB etch data or control	N/A	5.75 <sup>(1)</sup> –0.15	mil (mm)
	PCB etch clocks	N/A	5.75 <sup>(1)</sup> –0.15	mil (mm)
Minimum differential pair-to-pair spacing (S)	PCB etch data or control	N/A	20 (0.51)	mil (mm)
	PCB etch clocks	N/A	20 (0.51)	mil (mm)
	Escape routing in ball field	4 (0.1)	4 (0.1)	mil (mm)
Minimum line spacing to other signals (S)	PCB etch data or control	10 (0.25)	20 (0.51)	mil (mm)
	PCB etch clocks	20 (0.51)	20 (0.51)	mil (mm)
Maximum differential pair P-to-N length mismatch	Total data	N/A	12 –0.3	mil (mm)
	Total data	N/A	12 –0.3	mil (mm)

(1) Spacing may vary to maintain differential impedance requirements

**Table 6. DMD Interface Specific Routing**

SIGNAL GROUP LENGTH MATCHING				
INTERFACE	SIGNAL GROUP	REFERENCE SIGNAL	MAX MISMATCH	UNIT
DMD (LVDS)	SCTRL_AN, SCTRL_AP D_AP(15:0), D_AN(15:0)	DCK_AP/ DCKA_AN	± 150 (± 3.81)	mil (mm)
DMD (LVDS)	SCTRL_BN, SCTRL_BP D_BP(15:0), D_BN(15:0)	DCK_BP/ DCK_BN	± 150 (± 3.81)	mil (mm)

Number of layer changes:

- Single-ended signals: Minimize
- Differential signals: Individual differential pairs can be routed on different layers but the signals of a given pair should not change layers.

**Table 7. DMD Signal Routing Length<sup>(1)</sup>**

BUS	MIN	MAX	UNIT
DMD (LVDS)	50	375	mm

(1) Max signal routing length includes escape routing.

Stubs: Stubs should be avoided.

Termination Requirements: DMD interface: None – The DMD receiver is differentially terminated to 100 Ω internally.

Connector (DMD-LVDS interface bus only):

High-speed connectors that meet the following requirements should be used:

- Differential crosstalk: <5%
- Differential impedance: 75 to 125 Ω

Routing requirements for right-angle connectors: When using right-angle connectors, P-N pairs should be routed in the same row to minimize delay mismatch. When using right-angle connectors, propagation delay difference for each row should be accounted for on associated PCB etch lengths. Voltage or low frequency signals should be routed on the outer layers. Signal trace corners shall be no sharper than 45 degrees. Adjacent signal layers shall have the predominant traces routed orthogonal to each other.

These guidelines will produce a maximum PCB routing mismatch of 4.41 mm (0.174 inch) or approximately 30.4 ps, assuming 175 ps/inch FR4 propagation delay.

These PCB routing guidelines will result in approximately 25-ps system setup margin and 25-ps system hold margin for the DMD interface after accounting for signal integrity degradation as well as routing mismatch.

Both the DLPC900 output timing parameters and the DLP6500FLQ DMD input timing parameters include timing budget to account for their respective internal package routing skew.

### 10.2.1.1 Power Planes

Signal routing is NOT allowed on the power and ground planes. All device pin and via connections to this plane shall use a thermal relief with a minimum of four spokes. The power plane shall clear the edge of the PCB by 0.2”.

Prior to routing, vias connecting all digital ground layers (GND) should be placed around the edge of the rigid PWB regions 0.025” from the board edges with a 0.100” spacing. It is also desirable to have all internal digital ground (GND) planes connected together in as many places as possible. If possible, all internal ground planes should be connected together with a minimum distance between connections of 0.5”. Extra vias are not required if there are sufficient ground vias due to normal ground connections of devices. NOTE: All signal routing and signal vias should be inside the perimeter ring of ground vias.

Power and Ground pins of each component shall be connected to the power and ground planes with one via for each pin. Trace lengths for component power and ground pins should be minimized (ideally, less than 0.100”). Unused or spare device pins that are connected to power or ground may be connected together with a single via to power or ground. Ground plane slots are NOT allowed.

Route VOFFSET, VBIAS, and VRESET as a wide trace >20mils (wider if space allows) with 20 mils spacing.

### 10.2.1.2 LVDS Signals

The LVDS signals shall be first. Each pair of differential signals must be routed together at a constant separation such that constant differential impedance (as in section 10.1.2) is maintained throughout the length. Avoid sharp turns and layer switching while keeping lengths to a minimum. The distance from one pair of differential signals to another shall be at least 2 times the distance within the pair.

### 10.2.1.3 Critical Signals

The critical signals on the board must be hand routed in the order specified below. In case of length matching requirements, the longer signals should be routed in a serpentine fashion, keeping the number of turns to a minimum and the turn angles no sharper than 45 degrees. Avoid routing long trace all around the PCB.

**Table 8. Timing Critical Signals**

GROUP	SIGNAL	CONSTRAINTS	ROUTING LAYERS
1	D_AP(0:15), D_AN(0:15), DCLK_AP, DCLK_AN, SCTRL_AN, SCTRL_AP, D_BP(0:15), D_BN (0:15), DCLK_BP, DCLK_BN, SCTRL_BN, SCTRL_BP	Refer to <a href="#">Table 5</a> and <a href="#">Table 6</a>	Internal signal layers. Avoid layer switching when routing these signals.
2	RESET_ADDR(0:3), RESET_MODE(0:1), RESET_OEZ, RESET_SEL(0:1) RESET_STROBE, RESET_IRQZ.		Internal signal layers. Top and bottom as required.
3	SCP_CLK, SCP_DO, SCP_DI, SCP_ENZ.		Any
4	Others	No matching/length requirement	Any

#### **10.2.1.4 Flex Connector Plating**

Plate all the pad area on top layer of flex connection with a minimum of 35 and maximum 50 micro-inches of electrolytic hard gold over a minimum of 150 micro-inches of electrolytic nickel.

#### **10.2.1.5 Device Placement**

Unless otherwise specified, all major components should be placed on top layer. Small components such as ceramic, non-polarized capacitors, resistors and resistor networks can be placed on bottom layer. All high frequency de-coupling capacitors for the ICs shall be placed near the parts. Distribute the capacitors evenly around the IC and locate them as close to the device's power pins as possible (preferably with no vias). In the case where an IC has multiple de-coupling capacitors with different values, alternate the values of those that are side by side as much as possible and place the smaller value capacitor closer to the device.

#### **10.2.1.6 Device Orientation**

It is desirable to have all polarized capacitors oriented with their positive terminals in the same direction. If polarized capacitors are oriented both horizontally and vertically, then all horizontal capacitors should be oriented with the "+" terminal the same direction and likewise for the vertically oriented ones.

#### **10.2.1.7 Fiducials**

Fiducials for automatic component insertion should be placed on the board according to the following guidelines or on recommendation from manufacturer:

- Fiducials for optical auto insertion alignment shall be placed on three corners of both sides of the PWB.
- Fiducials shall also be placed in the center of the land patterns for fine pitch components (lead spacing <0.05").
- Fiducials should be 0.050 inch copper with 0.100 inch cutout (antipad).



## 11 Device and Documentation Support

### 11.1 Device Support

#### 11.1.1 Device Nomenclature

Table 9. Package Specific Information

PACKAGE TYPE	PINS	CONNECTOR
FLQ	203	LGA

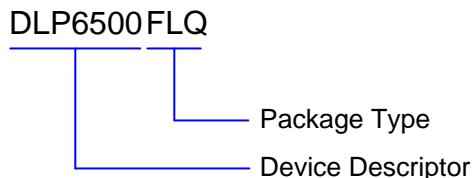

Figure 19. Part Number Description

#### 11.1.2 Device Markings

The device marking will include both human-readable information and a 2-dimensional matrix code. The human-readable information is described in Figure 20. The 2-dimensional matrix code is an alpha-numeric character string that contains the DMD part number, Part 1 of Serial Number, and Part 2 of Serial Number. The first character of the DMD Serial Number (part 1) is the manufacturing year. The second character of the DMD Serial Number (part 1) is the manufacturing month. The last character of the DMD Serial Number (part 2) is the bias voltage bin letter.

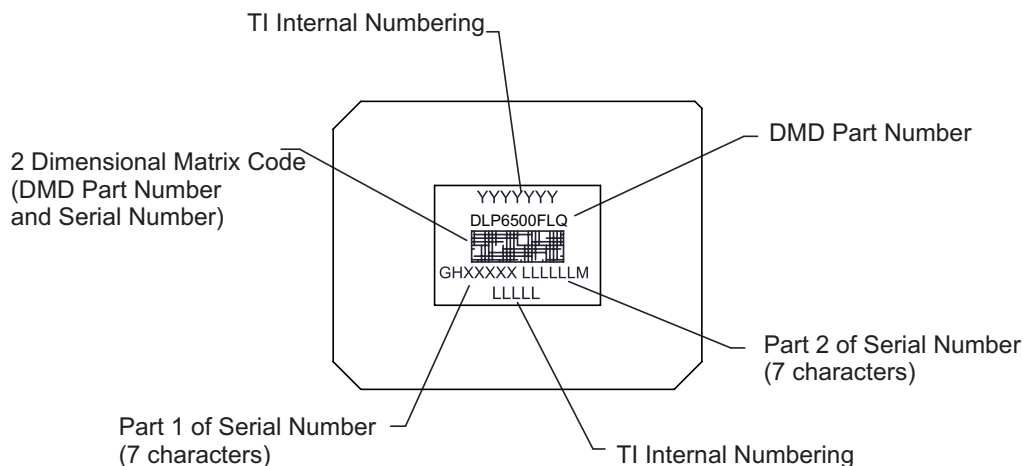

Figure 20. DMD Marking Locations

## 11.2 Documentation Support

### 11.2.1 Related Documentation

The following documents contain additional information related to the use of the DLP6500 device.

**Table 10. Related Documents**

DOCUMENT	
DLPC900 Digital Controller Data Sheet	<a href="#">DLPS037</a>
DLPC900 Software Programmer's Guide	<a href="#">DLPU018</a>

### 11.3 Trademarks

DLP is a trademark of Texas Instruments.  
All other trademarks are the property of their respective owners.

### 11.4 Electrostatic Discharge Caution



These devices have limited built-in ESD protection. The leads should be shorted together or the device placed in conductive foam during storage or handling to prevent electrostatic damage to the MOS gates.

### 11.5 Glossary

[SLYZ022](#) — *TI Glossary*.

This glossary lists and explains terms, acronyms, and definitions.

## 12 Mechanical, Packaging, and Orderable Information

The following pages include mechanical, packaging, and orderable information. This information is the most current data available for the designated devices. This data is subject to change without notice and revision of this document. For browser-based versions of this data sheet, refer to the left-hand navigation.

**PACKAGING INFORMATION**

Orderable Device	Status (1)	Package Type	Package Drawing	Pins	Package Qty	Eco Plan (2)	Lead/Ball Finish (6)	MSL Peak Temp (3)	Op Temp (°C)	Device Marking (4/5)	Samples
DLP6500FLQ	ACTIVE	CLGA	FLQ	203	1	Green (RoHS & no Sb/Br)	W NIAU	N / A for Pkg Type			Samples

(1) The marketing status values are defined as follows:

**ACTIVE:** Product device recommended for new designs.

**LIFEBUY:** TI has announced that the device will be discontinued, and a lifetime-buy period is in effect.

**NRND:** Not recommended for new designs. Device is in production to support existing customers, but TI does not recommend using this part in a new design.

**PREVIEW:** Device has been announced but is not in production. Samples may or may not be available.

**OBSELETE:** TI has discontinued the production of the device.

(2) Eco Plan - The planned eco-friendly classification: Pb-Free (RoHS), Pb-Free (RoHS Exempt), or Green (RoHS & no Sb/Br) - please check <http://www.ti.com/productcontent> for the latest availability information and additional product content details.

**TBD:** The Pb-Free/Green conversion plan has not been defined.

**Pb-Free (RoHS):** TI's terms "Lead-Free" or "Pb-Free" mean semiconductor products that are compatible with the current RoHS requirements for all 6 substances, including the requirement that lead not exceed 0.1% by weight in homogeneous materials. Where designed to be soldered at high temperatures, TI Pb-Free products are suitable for use in specified lead-free processes.

**Pb-Free (RoHS Exempt):** This component has a RoHS exemption for either 1) lead-based flip-chip solder bumps used between the die and package, or 2) lead-based die adhesive used between the die and leadframe. The component is otherwise considered Pb-Free (RoHS compatible) as defined above.

**Green (RoHS & no Sb/Br):** TI defines "Green" to mean Pb-Free (RoHS compatible), and free of Bromine (Br) and Antimony (Sb) based flame retardants (Br or Sb do not exceed 0.1% by weight in homogeneous material)

(3) MSL, Peak Temp. - The Moisture Sensitivity Level rating according to the JEDEC industry standard classifications, and peak solder temperature.

(4) There may be additional marking, which relates to the logo, the lot trace code information, or the environmental category on the device.

(5) Multiple Device Markings will be inside parentheses. Only one Device Marking contained in parentheses and separated by a "~" will appear on a device. If a line is indented then it is a continuation of the previous line and the two combined represent the entire Device Marking for that device.

(6) Lead/Ball Finish - Orderable Devices may have multiple material finish options. Finish options are separated by a vertical ruled line. Lead/Ball Finish values may wrap to two lines if the finish value exceeds the maximum column width.

**Important Information and Disclaimer:** The information provided on this page represents TI's knowledge and belief as of the date that it is provided. TI bases its knowledge and belief on information provided by third parties, and makes no representation or warranty as to the accuracy of such information. Efforts are underway to better integrate information from third parties. TI has taken and continues to take reasonable steps to provide representative and accurate information but may not have conducted destructive testing or chemical analysis on incoming materials and chemicals. TI and TI suppliers consider certain information to be proprietary, and thus CAS numbers and other limited information may not be available for release.

In no event shall TI's liability arising out of such information exceed the total purchase price of the TI part(s) at issue in this document sold by TI to Customer on an annual basis.



NOTES: UNLESS OTHERWISE SPECIFIED:

1. INTERPRET DIMENSIONS IN ACCORDANCE WITH ASME Y14.5M-1994.
2. DATUM A (SYSTEM INTERFACE PLANE) ESTABLISHED BY THREE DATUM AREAS SHOWN IN VIEW B (SHEET 2).
3. DATUM B ESTABLISHED BY TWO DATUM AREAS SHOWN IN VIEW B (SHEET 2).
4. DATUM C ESTABLISHED BY DATUM AREA SHOWN IN VIEW B (SHEET 2).
5. SUBSTRATE EDGE PERPENDICULARITY TOLERANCE APPLIES TO ENTIRE SURFACE
6. LOCALIZED BACKSIDE SURFACE FLATNESS APPLIES TO ENTIRE CERAMIC SURFACE.
7. DIE PARALLELISM TOLERANCE APPLIES TO DMD ACTIVE ARRAY ONLY.
8. DIE HEIGHT TOLERANCE APPLIES TO CENTER OF DMD ACTIVE ARRAY ONLY.
9. ROTATION ANGLE OF DMD ACTIVE ARRAY IS A REFINEMENT OF THE LOCATION TOLERANCE AND IS THE MAXIMUM VALUE ALLOWED.
10. SUBSTRATE INDEX MARK, SYMBOLIZATION PAD, SEAL RING, AND WINDOW FRAME TO BE ELECTRICALLY CONNECTED TO VSS PLANE IN SUBSTRATE.
11. WINDOW SHALL BE ORIENTED SUCH THAT WINDOW ID MARK ALIGNS WITH SUBSTRATE INDEX MARK AS SHOWN.
12. THE OUTER DIMENSIONS OF THE SYMBOLIZATION PAD REPRESENT THE APPROXIMATE SIZE AND LOCATION OF THE RECOMMENDED THERMAL INTERFACE AREA.
13. DMD ACTIVE ARRAY DIMENSIONS ARE RELATED TO DATUM A (PRIMARY), DATUM B (SECONDARY), AND DATUM C (TERTIARY).
14. ? IS A WILD CARD CHARACTER AND CAN BE ANY LETTER.

© COPYRIGHT 2008 TEXAS INSTRUMENTS UNPUBLISHED, ALL RIGHTS RESERVED.

REVISIONS			
REV	DESCRIPTION	DATE	APPROVED
A	ECO 2086120, INITIAL RELEASE	01/14/08	MAA
B	ECO 2086464, CHG INDEX MARK TOP	01/21/08	MAA
C	ECO 2087635, CHG GDT SYM PARALLEL FROM .001 TO .0008 IN SECTION A-A	03/03/08	MAA
D	ECO 2088011, CORRECTED PARALLELISM TYPO FROM [.0254] TO [.02032]	03/17/08	MAA

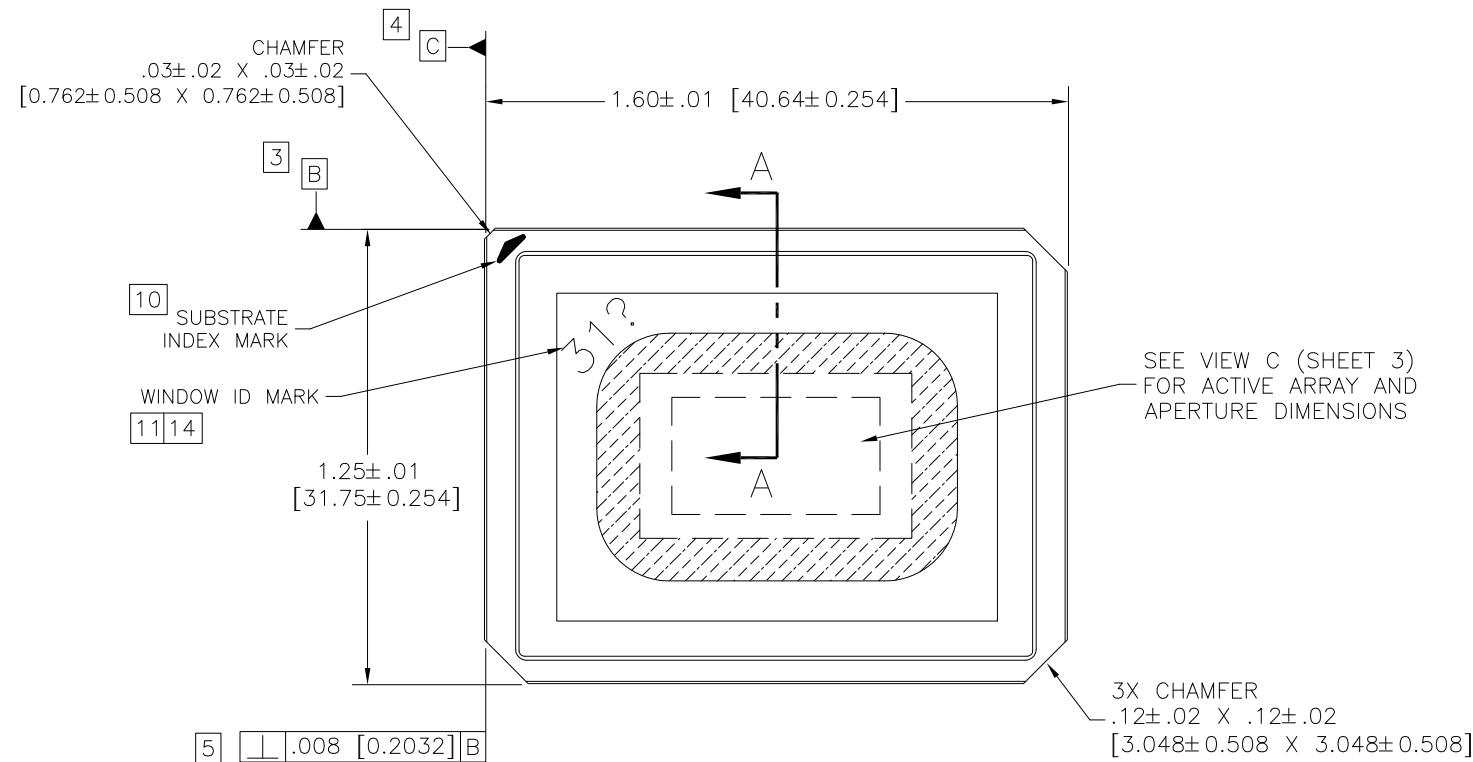
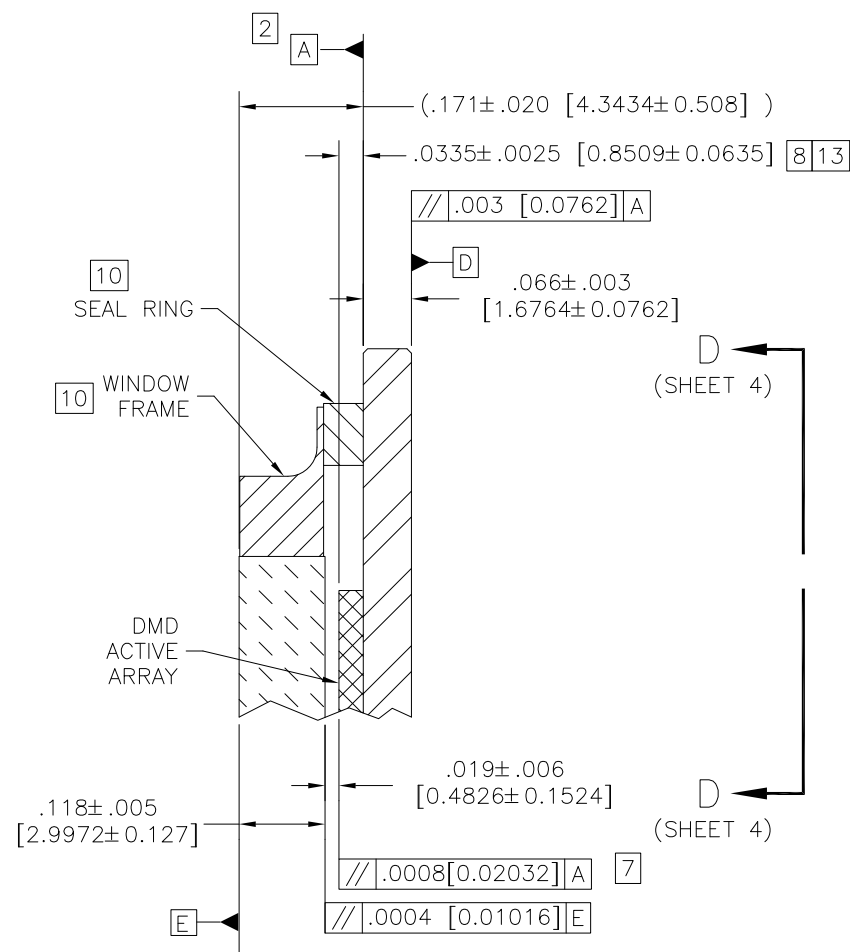

-1 QTY	ITEM NO	PART OR IDENTIFYING NUMBER	NOMENCLATURE OR DESCRIPTION	NOTES												
PARTS LIST																
			OWN M. AVERY DATE 01/01/08	 <b>TEXAS INSTRUMENTS</b> <i>Dallas, Texas</i> <b>ICD, MECHANICAL, DMD</b> <b>.65" 1080P 2XLVDS TYPE A</b>												
			ENGR M. AVERY 01/01/08													
			QA P. KONRAD 01/01/08													
			APVD													
		<table border="1"> <thead> <tr> <th colspan="2">HOLE TOLERANCE</th> </tr> </thead> <tbody> <tr> <td>.013 THRU .125</td> <td>+.004 -.001</td> </tr> <tr> <td>.126 THRU .250</td> <td>+.005 -.001</td> </tr> <tr> <td>.251 THRU .500</td> <td>+.006 -.001</td> </tr> <tr> <td>.501 THRU .750</td> <td>+.010 -.001</td> </tr> <tr> <td>1.000 THRU 2.000</td> <td>+.012 -.001</td> </tr> </tbody> </table>		HOLE TOLERANCE		.013 THRU .125	+.004 -.001	.126 THRU .250	+.005 -.001	.251 THRU .500	+.006 -.001	.501 THRU .750	+.010 -.001	1.000 THRU 2.000	+.012 -.001	
HOLE TOLERANCE																
.013 THRU .125	+.004 -.001															
.126 THRU .250	+.005 -.001															
.251 THRU .500	+.006 -.001															
.501 THRU .750	+.010 -.001															
1.000 THRU 2.000	+.012 -.001															
		<table border="1"> <thead> <tr> <th>SIZE</th> <th>DRAWING NO</th> <th>REV</th> </tr> </thead> <tbody> <tr> <td>C</td> <td>2509321</td> <td>D</td> </tr> </tbody> </table>		SIZE	DRAWING NO	REV	C	2509321	D							
SIZE	DRAWING NO	REV														
C	2509321	D														
		<table border="1"> <thead> <tr> <th>SCALE</th> <th>SHEET</th> </tr> </thead> <tbody> <tr> <td>3/1</td> <td>1 OF 4</td> </tr> </tbody> </table>		SCALE	SHEET	3/1	1 OF 4									
SCALE	SHEET															
3/1	1 OF 4															

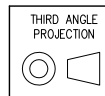

ACEC1g

DWG NO 2509321 SH 1

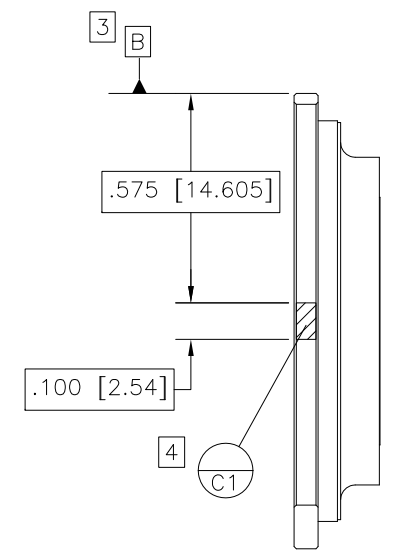
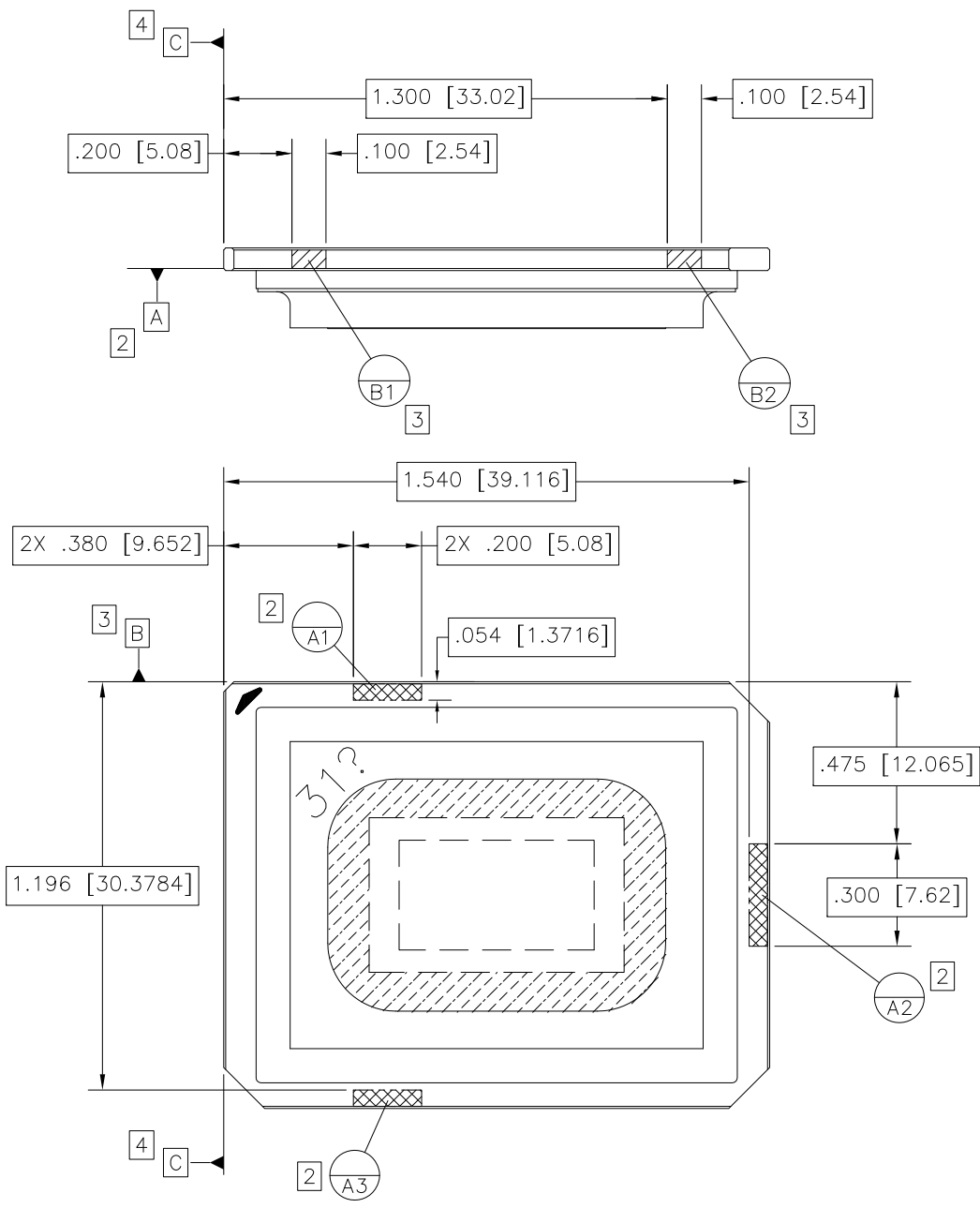
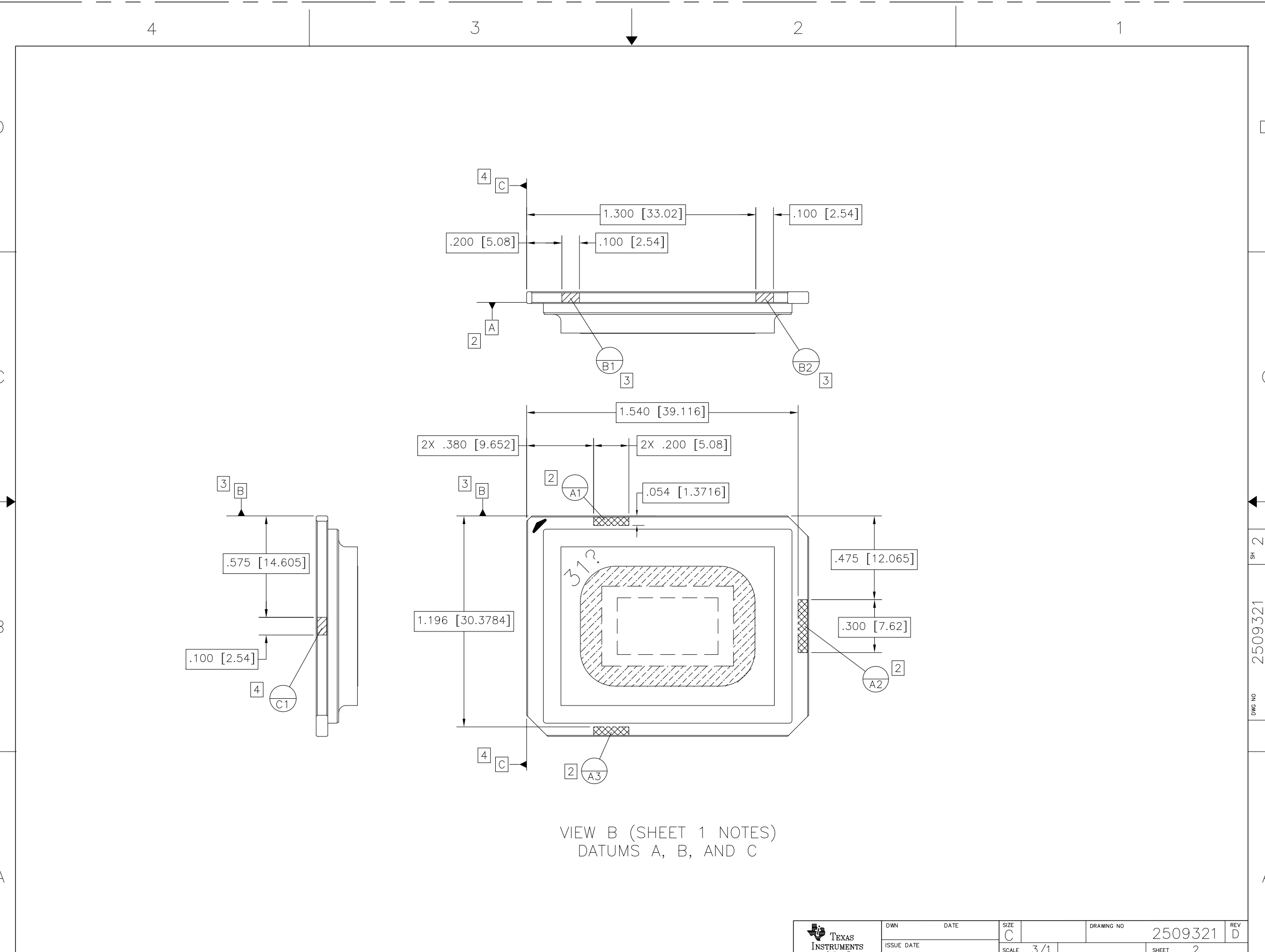

VIEW B (SHEET 1 NOTES)  
DATUMS A, B, AND C

DWG NO 2509321 SH 2

	DWN	DATE	SIZE	DRAWING NO	REV
	ISSUE DATE		C	2509321	D
			SCALE	3/1	SHEET
				2	

4

3

2

1

D

D

INCIDENT LIGHT

13

.5143±.006  
[13.06322±0.1524]

(.57146 [14.5152])  
DMD ACTIVE ARRAY

B 3

4 C

9 13

0.0°±0.8°  
(ANGLE)

.4643±.006  
[11.79322±0.1524]

13

(.3214 [8.1648])  
DMD ACTIVE ARRAY

.0699±.0105 [1.7744±0.2667]

.4530±.0020  
[11.5062±0.0508]

WINDOW SHIELD  
APERTURE

DMD  
ACTIVE ARRAY

.0918±.0105 [2.33124±0.2667]

.7470±.0020 [18.9738±0.0508]

VIEW C (SHEET 1)  
DMD ACTIVE ARRAY AND  
WINDOW SHIELD APERTURE

SHT 3

DWG NO 2509321

DWG NO

A

A

4

3

2

1

ACEC2c

 <b>TEXAS INSTRUMENTS</b> <i>Dallas, Texas</i>	DWN	DATE	SIZE	DRAWING NO	REV
	ISSUE DATE	SCALE	3/1	2509321	D
			SHEET	3	

20X  $\varnothing$ .054 $\pm$ .003 [1.3716 $\pm$ 0.0762]

$\varnothing$	$\varnothing$ .020	[0.508]	D	B	C
	$\varnothing$ .010	[0.254]	D		

29X .050 [1.27] = 1.450 [36.83]

.075 [1.905]

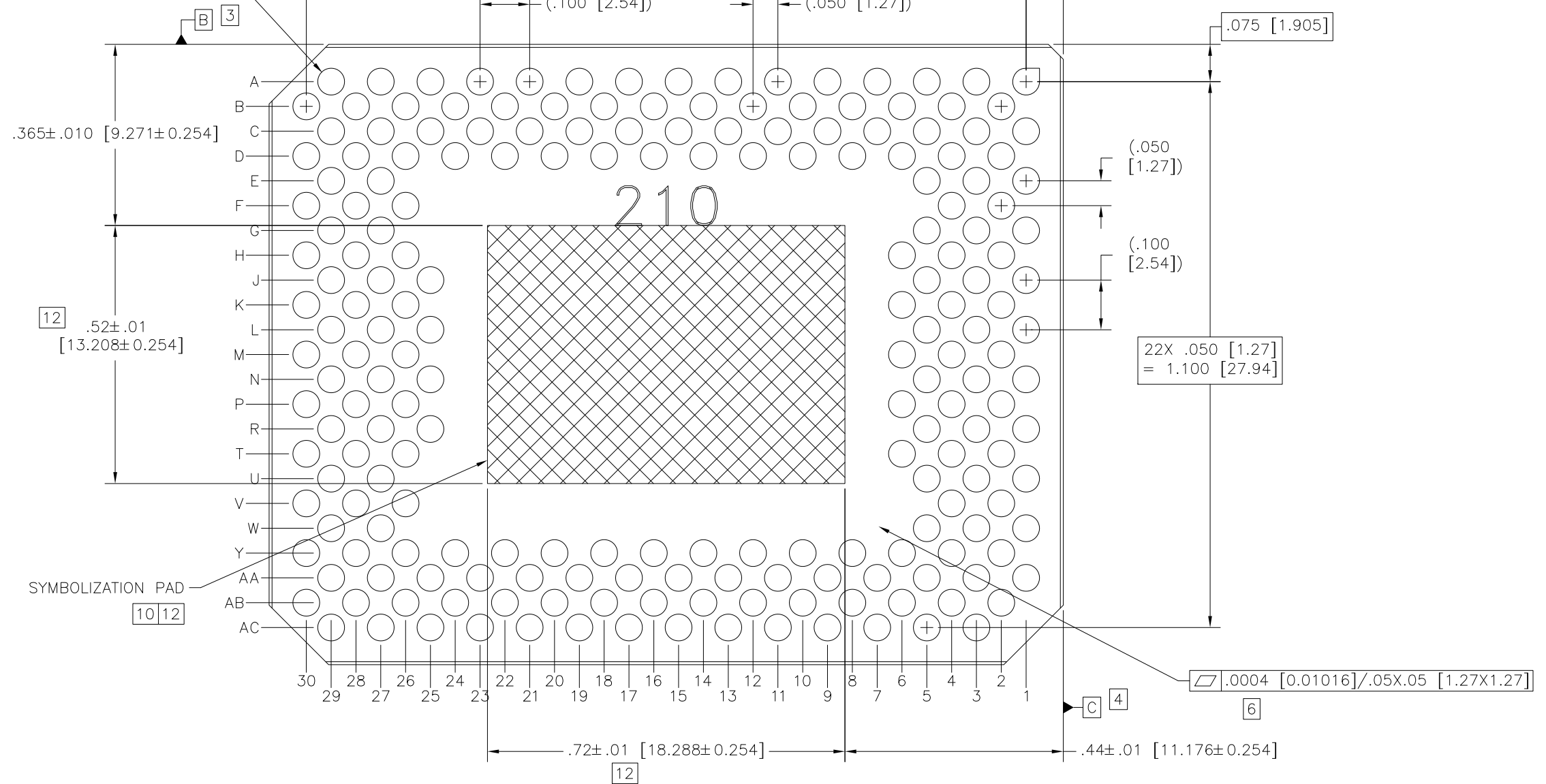

VIEW D-D (SHEET 1)  
SCALE 6/1

DWG NO 2509321 SH 4

 TEXAS INSTRUMENTS Dallas, Texas	DWN	DATE	SIZE	DRAWING NO	REV
	ISSUE DATE		C	2509321	D
			SCALE 3/1	SHEET 4	



## IMPORTANT NOTICE

Texas Instruments Incorporated and its subsidiaries (TI) reserve the right to make corrections, enhancements, improvements and other changes to its semiconductor products and services per JESD46, latest issue, and to discontinue any product or service per JESD48, latest issue. Buyers should obtain the latest relevant information before placing orders and should verify that such information is current and complete. All semiconductor products (also referred to herein as "components") are sold subject to TI's terms and conditions of sale supplied at the time of order acknowledgment.

TI warrants performance of its components to the specifications applicable at the time of sale, in accordance with the warranty in TI's terms and conditions of sale of semiconductor products. Testing and other quality control techniques are used to the extent TI deems necessary to support this warranty. Except where mandated by applicable law, testing of all parameters of each component is not necessarily performed.

TI assumes no liability for applications assistance or the design of Buyers' products. Buyers are responsible for their products and applications using TI components. To minimize the risks associated with Buyers' products and applications, Buyers should provide adequate design and operating safeguards.

TI does not warrant or represent that any license, either express or implied, is granted under any patent right, copyright, mask work right, or other intellectual property right relating to any combination, machine, or process in which TI components or services are used. Information published by TI regarding third-party products or services does not constitute a license to use such products or services or a warranty or endorsement thereof. Use of such information may require a license from a third party under the patents or other intellectual property of the third party, or a license from TI under the patents or other intellectual property of TI.

Reproduction of significant portions of TI information in TI data books or data sheets is permissible only if reproduction is without alteration and is accompanied by all associated warranties, conditions, limitations, and notices. TI is not responsible or liable for such altered documentation. Information of third parties may be subject to additional restrictions.

Resale of TI components or services with statements different from or beyond the parameters stated by TI for that component or service voids all express and any implied warranties for the associated TI component or service and is an unfair and deceptive business practice. TI is not responsible or liable for any such statements.

Buyer acknowledges and agrees that it is solely responsible for compliance with all legal, regulatory and safety-related requirements concerning its products, and any use of TI components in its applications, notwithstanding any applications-related information or support that may be provided by TI. Buyer represents and agrees that it has all the necessary expertise to create and implement safeguards which anticipate dangerous consequences of failures, monitor failures and their consequences, lessen the likelihood of failures that might cause harm and take appropriate remedial actions. Buyer will fully indemnify TI and its representatives against any damages arising out of the use of any TI components in safety-critical applications.

In some cases, TI components may be promoted specifically to facilitate safety-related applications. With such components, TI's goal is to help enable customers to design and create their own end-product solutions that meet applicable functional safety standards and requirements. Nonetheless, such components are subject to these terms.

No TI components are authorized for use in FDA Class III (or similar life-critical medical equipment) unless authorized officers of the parties have executed a special agreement specifically governing such use.

Only those TI components which TI has specifically designated as military grade or "enhanced plastic" are designed and intended for use in military/aerospace applications or environments. Buyer acknowledges and agrees that any military or aerospace use of TI components which have **not** been so designated is solely at the Buyer's risk, and that Buyer is solely responsible for compliance with all legal and regulatory requirements in connection with such use.

TI has specifically designated certain components as meeting ISO/TS16949 requirements, mainly for automotive use. In any case of use of non-designated products, TI will not be responsible for any failure to meet ISO/TS16949.

### Products

Audio	<a href="http://www.ti.com/audio">www.ti.com/audio</a>
Amplifiers	<a href="http://amplifier.ti.com">amplifier.ti.com</a>
Data Converters	<a href="http://dataconverter.ti.com">dataconverter.ti.com</a>
DLP® Products	<a href="http://www.dlp.com">www.dlp.com</a>
DSP	<a href="http://dsp.ti.com">dsp.ti.com</a>
Clocks and Timers	<a href="http://www.ti.com/clocks">www.ti.com/clocks</a>
Interface	<a href="http://interface.ti.com">interface.ti.com</a>
Logic	<a href="http://logic.ti.com">logic.ti.com</a>
Power Mgmt	<a href="http://power.ti.com">power.ti.com</a>
Microcontrollers	<a href="http://microcontroller.ti.com">microcontroller.ti.com</a>
RFID	<a href="http://www.ti-rfid.com">www.ti-rfid.com</a>
OMAP Applications Processors	<a href="http://www.ti.com/omap">www.ti.com/omap</a>
Wireless Connectivity	<a href="http://www.ti.com/wirelessconnectivity">www.ti.com/wirelessconnectivity</a>

### Applications

Automotive and Transportation	<a href="http://www.ti.com/automotive">www.ti.com/automotive</a>
Communications and Telecom	<a href="http://www.ti.com/communications">www.ti.com/communications</a>
Computers and Peripherals	<a href="http://www.ti.com/computers">www.ti.com/computers</a>
Consumer Electronics	<a href="http://www.ti.com/consumer-apps">www.ti.com/consumer-apps</a>
Energy and Lighting	<a href="http://www.ti.com/energy">www.ti.com/energy</a>
Industrial	<a href="http://www.ti.com/industrial">www.ti.com/industrial</a>
Medical	<a href="http://www.ti.com/medical">www.ti.com/medical</a>
Security	<a href="http://www.ti.com/security">www.ti.com/security</a>
Space, Avionics and Defense	<a href="http://www.ti.com/space-avionics-defense">www.ti.com/space-avionics-defense</a>
Video and Imaging	<a href="http://www.ti.com/video">www.ti.com/video</a>

### TI E2E Community

[e2e.ti.com](http://e2e.ti.com)